

**RE SERIES MARINE E⁴
ELECTRIC FRYERS**
Installation, Operation, Service and Parts Manual



FPRE 17 kW & 22 kW

 **Frymaster**[®]



Frymaster, a member of the Commercial Food Equipment Service Association, recommends using CFESA Certified Technicians.

24-Hour Service Hotline 1-800-551-8633

NOVEMBER 2011

*** 8196202A ***

www.frymaster.com

Email: service@frymaster.com

NOTICE

IF, DURING THE WARRANTY PERIOD, THE CUSTOMER USES A PART FOR THIS MANITOWOC FOOD SERVICE EQUIPMENT OTHER THAN AN **UNMODIFIED** NEW OR RECYCLED PART PURCHASED DIRECTLY FROM FRYMASTER DEAN, OR ANY OF ITS AUTHORIZED SERVICERS, AND/OR THE PART BEING USED IS MODIFIED FROM ITS ORIGINAL CONFIGURATION, THIS WARRANTY WILL BE VOID. FURTHER, FRYMASTER DEAN AND ITS AFFILIATES WILL NOT BE LIABLE FOR ANY CLAIMS, DAMAGES OR EXPENSES INCURRED BY THE CUSTOMER WHICH ARISE DIRECTLY OR INDIRECTLY, IN WHOLE OR IN PART, DUE TO THE INSTALLATION OF ANY MODIFIED PART AND/OR PART RECEIVED FROM AN UNAUTHORIZED SERVICER.

 DANGER

Copper wire suitable for at least 167°F (75°C) must be used for power connections.

 DANGER

The electrical power supply for this appliance must be the same as indicated on the rating and serial number plate located on the inside of the fryer door.

 DANGER

This appliance must be connected to the voltage and phase as specified on the rating and serial number plate located on the inside of the fryer door.

 DANGER

All wiring connections for this appliance must be made in accordance with the wiring diagrams furnished with the equipment. Wiring diagrams are located on the inside of the fryer door.

 DANGER

Do not store or use gasoline or other flammable vapors and liquids in the vicinity of this or any other appliance.

NOTICE

Drawings and photos used in this manual are intended to illustrate operational, cleaning and technical procedures. They may differ slightly in appearance or placement between fryers but functionality should remain the same. They may not conform to onsite management operational procedures.

 WARNING

Frymaster fryers equipped with legs are for permanent installations. Fryers fitted with legs must be lifted during movement to avoid damage and possible bodily injury. For a moveable or portable installation, Frymaster optional equipment casters must be used. Questions? Call 1-800-551-8633 or email: service@frymaster.com

 DANGER

The front ledge of the fryer is not a step. Do not stand on the fryer. Serious injury can result from slips or contact with the hot oil.

 WARNING

This equipment is intended for indoor use only. Do not install or operate this equipment in outdoor areas.

NOTICE

This appliance is intended for professional use only and is to be operated by qualified personnel only. A Frymaster DEAN Factory Authorized Servicer (FAS) or other qualified professional should perform installation, maintenance, and repairs. Installation, maintenance, or repairs by unqualified personnel may void the manufacturer's warranty.

NOTICE

This equipment must be installed in accordance with the appropriate national and local codes of the country and/or region in which the appliance is installed.

NOTICE TO U.S. CUSTOMERS

This equipment is to be installed in compliance with the basic plumbing code of the Building Officials and Code Administrators International, Inc. (BOCA) and the Food Service Sanitation Manual of the U.S. Food and Drug Administration.

 WARNING

No structural material on the fryer should be altered or removed to accommodate placement of the fryer under a hood. Questions? Call the Frymaster Dean Service Hotline at 1-800-551-8633.

NOTICE TO OWNERS OF UNITS EQUIPPED WITH COMPUTERS

U.S.

This device complies with Part 15 of the FCC rules. Operation is subject to the following two conditions: 1) This device may not cause harmful interference, and 2) This device must accept any interference received, including interference that may cause undesired operation. While this device is a verified Class A device, it has been shown to meet the Class B limits.

CANADA

This digital apparatus does not exceed the Class A or B limits for radio noise emissions as set out by the ICES-003 standard of the Canadian Department of Communications.

Cet appareil numérique n'émet pas de bruits radioélectriques dépassant les limites de classe A et B prescrites dans la norme NMB-003 édictée par le Ministre des Communications du Canada.

 DANGER

Improper installation, adjustment, maintenance or service, and unauthorized alterations or modifications can cause property damage, injury, or death. Read the installation, operating, and service instructions thoroughly before installing or servicing this equipment.

 DANGER

The crumb tray in fryers equipped with a filter system must be emptied into a fireproof container at the end of frying operations each day. Some food particles can spontaneously combust if left soaking in certain shortening material.

 WARNING

Do not bang fry baskets or other utensils on the fryer's joiner strip. The strip is present to seal the joint between the frypots. Banging fry baskets on the strip to dislodge shortening will distort the strip, adversely affecting its fit. It is designed for a tight fit and should only be removed for cleaning.

 WARNING

Never spray the fryer with water or use water jets to clean the fryer.



**RE Series Marine Electric Fryers
Installation, Operation, Service and Parts Manual**

TABLE OF CONTENTS

CHAPTER 1: Introduction

1.1	General	1-1
1.2	Safety Information.....	1-1
1.3	Controller Information	1-2
1.4	Shipping Damage Claim Procedure	1-2
1.5	Service Information	1-2

CHAPTER 2: Installation Instructions

2.1	Introduction	2-1
2.2	Power Requirements.....	2-2
2.3	Installation	2-3
2.4	After the Fryers are Anchored at the Frying Station	2-3
2.5	Dimensions and Weights.....	2-4

CHAPTER 3: Operating Instructions

3.1	Equipment Setup and Shutdown Procedures.....	3-1
3.2	Operation of the Solid-State Digital Controller	3-2

CHAPTER 4: Filtration Instructions

4.1	Introduction	4-1
4.2	Preparing the Filter for Use	4-1
4.3	Operation of the Filter	4-3
4.4	Draining and Disposing of Waste Oil	4-5

CHAPTER 5: Preventive Maintenance

5.1	Cleaning the Fryer	5-1
5.1.1	Clean Inside and Outside of the Fryer Cabinet	5-1
5.1.2	Clean the Built in Filtration System	5-1
5.1.3	Clean the Frypot and Heating Elements (Boil-Out)	5-2
5.1.4	Clean Detachable Parts and Accessories	5-3
5.2	Annual/Periodic System Inspection	5-3

CHAPTER 6: Operator Troubleshooting

6.1	Introduction	6-1
6.2	Troubleshooting.....	6-2
6.2.1	Control and Heating Problems	6-2
6.2.2	Filtration Problems	6-4

CHAPTER 7: Service Procedures

7.1	General	7-1
7.2	Replacing a Remote Digital Controller	7-1
7.3	Replacing Component Box Components	7-1
7.4	Replacing a High-Limit Thermostat.....	7-2
7.5	Replacing a Temperature Probe	7-3
7.6	Replacing a Heating Element	7-4
7.7	Replacing Contactor Box Components	7-6
7.8	Replacing a Frypot	7-7
7.9	Built in Filtration System Service Procedures	7-9
7.9.1	Filtration System Problem Resolution	7-9
7.9.2	Replacing the Filter Motor, Filter Pump and Related Components	7-10
7.9.3	Replacing the Filter Transformer or Filter Relay	7-11
7.10	Interface Board Diagnostic Chart.....	7-12
7.11	Probe Resistance Chart.....	7-13
7.12	Wiring Diagram, Simplified RE17.....	7-14
7.13	Wiring Diagram, System.....	7-15
7.14	Wiring Diagram, Contactor Box	7-16
7.15	Wiring Diagram, Wiring Harnesses	7-17
7.16	Wiring Diagram, Remote Cable	7-18

CHAPTER 8: Parts List

8.1	Accessories	8-1
8.2	Cabinetry	8-2
8.2.1	Backs, Panels, Doors, Handles, Sides, Tilt Housings & Topcaps.....	8-2
8.2.2	Cabinet Bases, Braces and Associated Parts	8-4
8.2.2.1	FPRE117 Single	8-4
8.2.2.2	FPRE217 Double.....	8-6
8.3	Drain System Components.....	8-8
8.3.1	FPRE217 Euro-Look Drain Tube Sections and Parts	8-8
8.3.2	Drain Valve Assembly and Component Parts.....	8-9
8.3.2.1	FPRE117 Single Drain Valve Assembly.....	8-9
8.3.2.2	FPRE217 Euro-Look Drain Valve Assembly	8-10
8.4	Electronics and Wiring Components.....	8-11
8.4.1	Component Boxes	8-11
8.4.2	Contactor Boxes	8-12
8.4.3	Terminal Blocks	8-14
8.4.4	Heating Element Assembly and Associated Parts.....	8-15
8.4.5	Remote Digital Controller	8-17

8.4.6	Wiring Assemblies and Harnesses	8-17
8.4.6.1	Contactor Box Wiring Assembly 12-Pin.....	8-17
8.4.6.2	Contactor Box Wiring Assembly 6-Pin Left Element.....	8-17
8.4.6.3	Contactor Box Wiring Assembly 9-Pin Right Element	8-18
8.4.6.4	Main Wiring Harness	8-18
8.4.6.5	Component Box Wiring Harness	8-18
8.5	Filtration System Components	8-19
8.5.1	FPRE117 Single Filtration Components	8-19
8.5.2	FPRE217 Filtration Components	8-21
8.6	Frypot Assembly and Thermostat	8-23
8.7	FPRE217 Oil Return System Components	8-23
8.8	Oil Disposal Plumbing	8-25
8.9	Wiring Connectors, Pin Terminals, Seals and Power Cords	8-26
8.10	Fasteners.....	8-28

RE SERIES MARINE E⁴ ELECTRIC FRYERS

CHAPTER 1: INTRODUCTION

1.1 General

Read the instructions in this manual thoroughly before attempting to operate this equipment. This manual covers all configurations of RE Series Electric Fryer models specifically configured for use aboard surface ships, including FPRE117/122 kW and FPRE217/222 kW models. The fryers in this model family have most parts in common, and when discussed as a group, will be referred to as “RE Series Marine Electric” fryers.

The RE Series Marine Electric fryers feature a built-in filtration system and also include features such as deep cold-zones and open frypots with rotating elements. These fryers are equipped with remote mounted solid-state digital controllers. Fryers in this series can be single units or grouped in batteries of two or more fryers.

1.2 Safety Information

Before attempting to operate your unit, read the instructions in this manual thoroughly.

Throughout this manual, you will find notations enclosed in double-bordered boxes similar to the one below.

 **DANGER**

Hot cooking oil causes severe burns. Never attempt to move a fryer containing hot oil or to transfer hot oil from one container to another.

 **CAUTION** boxes contain information about actions or conditions that *may cause or result in a malfunction of your system.*

 **WARNING** boxes contain information about actions or conditions that *may cause or result in damage to your system,* and which may cause your system to malfunction.

 **DANGER** boxes contain information about actions or conditions that *may cause or result in injury to personnel,* and which may cause damage to your system and/or cause your system to malfunction.

Fryers in this series are equipped with the following automatic safety features:

1. Two high-temperature detection features one of which sounds an alarm and the other shuts off power to the elements should the temperature control fail and the temperature continue to rise.
2. A safety switch built into the drain valve, which prevents the elements from heating with the drain valve even partially open.
3. A magnetic tilt switch that shuts off the elements when lifted for frypot cleaning.

1.3 Controller Information

This equipment has been tested and found to comply with the limits for a Class A digital device, pursuant to Part 15 of the FCC rules. While this device is a verified Class A device, it has been shown to meet the Class B limits. These limits are designed to provide reasonable protection against harmful interference when the equipment is operated in a commercial environment. This equipment generates, uses and can radiate radio frequency energy and, if not installed and used in accordance with the instruction manual, may cause harmful interference to radio communications.

The user may find the following booklet prepared by the Federal Communications Commission helpful: "How to Identify and Resolve Radio-TV Interference Problems". This booklet is available from the U.S. Government Printing Office, Washington, DC 20402, Stock No. 004-000-00345-4.

1.4 Shipping Damage Claim Procedure

What to do if this equipment arrives damaged:

Please note that this equipment was carefully inspected and packed by skilled personnel before leaving the factory. The freight company assumes full responsibility for safe delivery upon acceptance of the equipment.

1. File Claim for Damages Immediately—Regardless of extent of damage.
2. Visible Loss or Damage—Be sure this is noted on the freight bill or express receipt and is signed by the person making the delivery.
3. Concealed Loss or Damage—If damage is unnoticed until equipment is unpacked, notify the freight company or carrier immediately and file a concealed damage claim. This should be done within 15 days of date of delivery. Be sure to retain container for inspection.

1.5 Service Information

For non-routine maintenance or repairs, or for service information, contact your local Frymaster Authorized Servicer (FAS). A list of Frymaster Factory Authorized Servicers (FAS's) is located on the Frymaster website at www.frymaster.com. Service information may also be obtained by calling the Frymaster Technical Services Department at 1-800-551-8633 or via e-mail at service@frymaster.com. The following information will be needed in order to assist you efficiently:

Model Number: _____
Serial Number: _____
Voltage: _____

Also be prepared to describe the specific problem.

RETAIN AND STORE THIS MANUAL IN A SAFE PLACE FOR FUTURE USE.

RE SERIES MARINE E⁴ ELECTRIC FRYERS

CHAPTER 2: INSTALLATION INSTRUCTIONS

2.1 Introduction

The instructions in this chapter cover all configurations of RE Series Marine Electric Fryer models specifically configured for use aboard surface ships, including FPRE117/122 kW and FPRE217/222 kW models. The instructions do not cover and may not be used for installations ashore.

Proper installation is essential for the safe, efficient, trouble-free operation of this appliance. Any unauthorized alteration of this equipment will void the Frymaster warranty.

NOTICE

All fryers shipped without factory supplied cords and plug assemblies must be hardwired using flexible conduit to the terminal block located on the rear of the fryer. These fryers should be wired to NEC specifications. Hardwired units must include installation of restraint devices.

DANGER

Adequate means must be provided to limit the movement of this appliance without depending on or transmitting stress to the electrical conduit.

NOTICE

If this equipment is wired directly into the electrical power supply, a means for disconnection from the supply having a contact separation of at least 3-mm in all poles must be incorporated in the fixed wiring.

NOTICE

This equipment must be positioned so that the plug is accessible unless other means for disconnection from the power supply (e.g., a circuit breaker) is provided.

NOTICE

If this appliance is permanently connected to fixed wiring, it must be connected by means of copper wires having a temperature rating of not less than 167°F (75°C).

NOTICE

If the electrical power supply cord is damaged, it must be replaced by a Frymaster Dean Factory Authorized Servicer technician or a similarly qualified person in order to avoid a hazard.

DANGER

This appliance must be connected to a power supply having the same voltage and phase as specified on the rating plate located on the inside of the appliance door.

⚠ DANGER

All wiring connections for this appliance must be made in accordance with the wiring diagram(s) furnished with the appliance. Refer to the wiring diagram(s) affixed to the inside of the appliance door when installing or servicing this equipment.

⚠ DANGER

The appliance area must be kept free and clear of combustible material at all times.

⚠ WARNING

Do not block the area around the base or under the fryers.

All installation and service on FRYMASTER equipment must be performed by qualified, certified, licensed, and/or authorized installation or service personnel.

Service may be obtained by contacting a local Frymaster DEAN Factory Authorized Servicer.

In the event of a power failure, the fryer(s) will automatically shut down. If this occurs, turn the power switch OFF. Do not attempt to start the fryer(s) until power is restored.

A clearance of 6 inches (15cm) must be provided at both sides and back adjacent to combustible construction. A minimum of 24 inches (61cm) should be provided at the front of the equipment for servicing and proper operation.

Connections should be made by means of an approved, flexible-metallic or rubber-covered electrical cable and quick-disconnect plug. The fryers may be installed with “hard-wired” connections, but use of quick-disconnect plugs will facilitate service if required. Connections are made to the fryer power input terminal block located in the lower back of the fryer(s).

2.2 Power Requirements

Use copper wire ONLY, suitable for at least 167°F (75°C)						
MODEL	VOLTAGE	PHASE	WIRE SERVICE	MINIMUM WIRE SIZE		AMPS (per leg)
				AWG	mm	
FPRE117	440	3	3	6	(4.11)	23
FPRE117	480	3	3	6	(4.11)	21
FPRE122	440	3	3	6	(4.11)	29
FPRE122	480	3	3	6	(4.11)	27
FPRE217 (Per Vat)	440	3	3	6	(4.11)	23
FPRE217 (Per Vat)	480	3	3	6	(4.11)	21
FPRE222 (Per Vat)	440	3	3	6	(4.11)	29
FPRE222 (Per Vat)	480	3	3	6	(4.11)	27

RE Series Marine electric fryers are equipped with a filter system that requires a separate 120VAC or 220VAC depending on configuration, single-phase, 3-wire, 20 amp service (refer to wiring diagram on page 7-15).

NOTICE

If this appliance is permanently connected to fixed wiring, it must be connected by means of copper wires having a temperature rating of not less than 167°F (75°C).

⚠ DANGER

This appliance must be connected to a power supply having the same voltage and phase as specified on the rating plate located on the inside of the appliance door.

⚠ DANGER

All wiring connections for this appliance must be made in accordance with the wiring diagram(s) furnished with the appliance. Refer to the wiring diagram(s) affixed to the inside of the appliance door when installing or servicing this equipment.

2.3 Installation

Shipboard installations are often unique, however, here's a list of do's and don'ts to avoid trouble:

Do ensure the fryer is adequately attached to the deck.

Do ensure the fryer is mounted well away from appliances, which are sprayed with water.

Do mount the remote controller within easy reach of the operator and away from the heat and vapors of the fryer vat and other cooking equipment.

Do remove the 15-pin plug from the controller cable with a pin pusher before routing it to the fryer and carefully reattach, using the provided diagram in section 7.15.

Don't mount the remote controller on the fryer's flue cap or on the bulkhead above the fryer vat.

Don't cut and splice the remote controller's cable to facilitate routing it to the fryer.



DO use a pin pusher to remove the 15-pin plug on the controller cable for routing.



DO NOT mount the controller on the fryer's flue cap or on the bulkhead above the fryer's vat.

⚠ DANGER

No structural material on the fryer should be altered or removed to accommodate placement of the fryer under a hood. Questions? Call the Frymaster Dean Service Department at 1-800-551-8633 or via e-mail at service@frymaster.com

⚠ DANGER

Hot oil can cause severe burns. Avoid contact. Under all circumstances, oil must be removed from the fryer before attempting to move it to avoid oil spills, falls and severe burns. This fryer may tip and cause personal injury if not secured in a stationary position.

2.4 After Fryers Are Anchored At the Frying Station

1. Close frypot drain-valve(s) and fill frypot(s) with water to the bottom oil level line.
2. Boil out frypot(s) in accordance with the instructions in Section 5.1.3 of this manual.
3. Drain, clean, and fill frypot(s) with cooking oil. (See *Equipment Setup and Shutdown Procedures* in Chapter 3.)

RE SERIES MARINE E⁴ ELECTRIC FRYERS

CHAPTER 3: OPERATING INSTRUCTIONS

3.1 Equipment Setup and Shutdown Procedures

Setup

 **DANGER**

Never operate the appliance with an empty frypot. The frypot must be filled with water, oil or shortening before energizing the elements. Failure to do so will result in irreparable damage to the elements and may cause a fire.

 **DANGER**

Remove all drops of water from the frypot before filling with oil or shortening. Failure to do so will cause spattering of hot liquid when the oil or shortening is heated to cooking temperature.

1. Fill the frypot with oil to the bottom OIL LEVEL line located on the rear of the frypot. This will allow for oil expansion as heat is applied. Do not fill cold oil any higher than the bottom line; overflow may occur as heat expands the oil.

NOTE: If solid shortening is used, first raise the elements, then pack the shortening into the bottom of the frypot. Lower the elements, and then pack the shortening around and over the elements to the lower mark. It may be necessary to add shortening to bring the level up to the upper mark after the packed shortening has melted. Cooking oil/shortening capacity of H17 series fryer is 50 lbs. (25 liters) at 70°F (21°C).

 **DANGER**

Never set a complete block of solid shortening on top of the heating elements.

When using solid shortening, always pre-melt the shortening before adding it to the frypot. If the shortening is not pre-melted, it must be packed down into the bottom of the frypot and between the elements, and the fryer must be started in the melt-cycle mode.

Never cancel the melt-cycle mode when using solid shortening. Doing so will result in damage to the elements and increase the potential for a flash fire.

2. Replace the basket support rack on top of the heating elements.
3. If the fryer is not hard-wired into the power supply, ensure that the power cord is plugged into the appropriate receptacle. Verify that the face of the plug is flush with the outlet plate, with no portion of the prongs visible.

- Ensure that the oil level is at the *top* OIL LEVEL line when the oil *is at its cooking temperature*. It may be necessary to add oil to bring the level up to the upper mark, *after it has reached cooking temperature*.

Shutdown

- Turn the fryer off.
- Filter the oil and clean the fryers (See Chapters 4 and 5).

3.2 Operation of the Solid-State Digital Controller (operation of other controllers is covered in the Frymaster Controllers Manual PN 819-5616)

NOTE: Refer to Chapter 4 of this manual for operating instructions for the built-in filtration system.

Fryers configured for marine use are equipped with remotely mounted solid-state digital controllers.

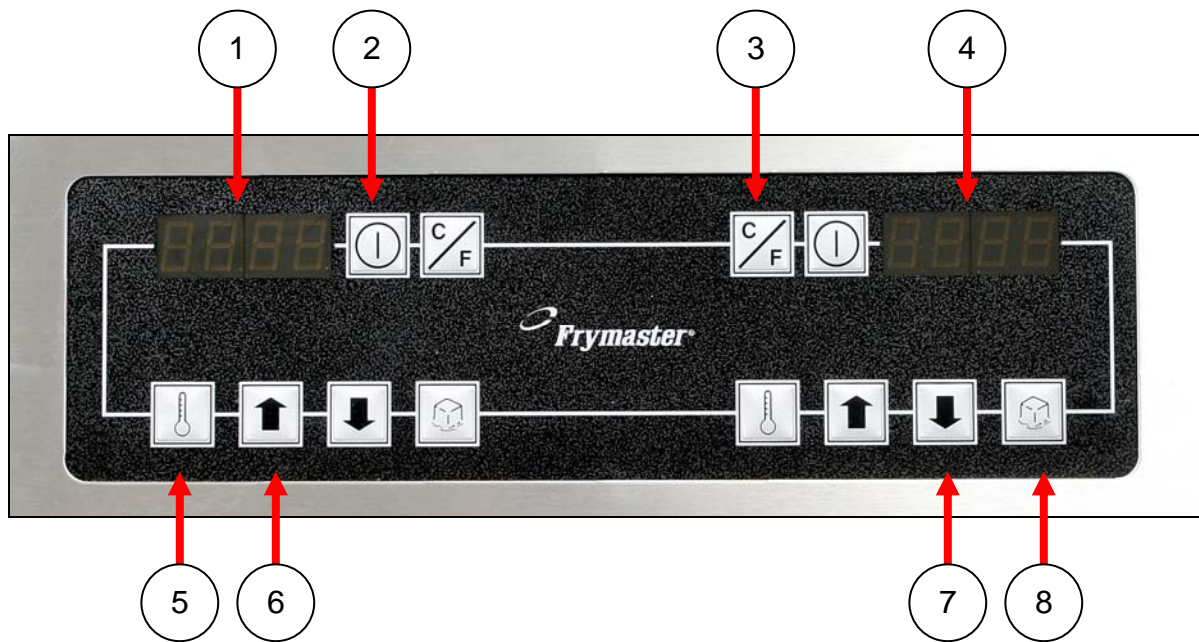

Marine Solid-State Digital Controller

ITEM	DESCRIPTION
1	Lighted Display – LED display for a full-pot fryer. Displays setpoint temperature.
2	On/Off Switch – Switches the power On or Off.
3	C/F Switch – Toggles the display between Fahrenheit and Celsius
4	Lighted Display- LED Display – Displays current frypot temperature and heat mode light (decimal) will alternately illuminate as the elements cycle on and off.
5	Temperature / Setpoint Display Switch –Toggles the display between frypot temperature and setpoint temperature.
6	Up Arrow – Raises setpoint temperature.
7	Down Arrow – Lowers the setpoint temperature.
8	Melt-Cycle Cancel Switch – Cancels the melt-cycle mode.

The digital controller, illustrated above, is used to maintain oil at the temperature indicated by the controller.

The fryer has two built-in high-limit protection features. If the temperature in the frypot reaches 411°F (210°C), an alarm will sound. In the event that the temperature continues to rise, there is a second and separate high limit circuit that will shut down the system at 425° (218°C), sound an alarm and display “help”.

A shunt trip device is integrated into the marine specifications. The shunt trip is a contact, which is closed by a coil in the fryer’s 24-volt safety circuit. Leads from the shunt trip extend from the fryer and can be wired to a specialized shipboard circuit breaker. Voltage from the ship passes through the closed shunt trip on the fryer, keeping the ship’s circuit breaker closed. If the fryer’s safety circuit opens due to the high-limit opening or the opening of a drain valve while the fryer is on, the shunt-trip circuit on the fryer opens, which opens the ship’s circuit breaker, killing power to the fryer.

The digital controller has no timing features, so the operator must monitor cooking.

 **WARNING**
Before pressing the power switch to the ON position, ensure that the frypot is properly filled with oil. See Section 3.1.

CONTROLLER OPERATING PROCEDURE

1. Turn the power switch ON.
2. Verify that the control is set to the desired cooking temperature.
3. Press the power switch to the ON position. The POWER light will illuminate.
4. If the frypot temperature is below 180°F (82°C), the controller will automatically enter a warm-up cycle (often called a melt cycle). The heating elements will cycle on and off repeatedly, allowing the oil to heat gradually, without scorching. During the warm-up cycle, the heating mode light (decimal point) will alternately illuminate and go off as the elements cycle on and off. When the frypot temperature reaches 180°F (82°C), the controller will exit the warm-up cycle and the heating mode light will remain continuously illuminated.
5. When the oil temperature reaches the setpoint, the elements will cycle OFF and the HEAT light will go off, indicating that the fryer is ready for the cooking process to begin.

INTRODUCTION

The Digital Controller allows the operator to program the frypot setpoint and to toggle the display between the frypot temperature and the programmed setpoint. The setpoint is an operator-determined frying temperature. When the controller is turned on, it automatically brings the cooking oil to the setpoint and maintains it at that temperature until the controller is turned off. Units display the setpoint by default. This controller also features a programmable melt-cycle cancel switch and a switch for toggling the temperature display between Fahrenheit and Celsius as well as toggling between the setpoint and the actual temperature.

The controller has three error display messages:

HELP, indicating a heating problem or drain valve problem. Turn the fryer off reset the drain handle and try again. If the error still appears, call the Frymaster hotline.

HOT and actual frypot temperature, indicating that the shortening temperature is above 411°F (210°C). If this display is seen, turn the fryer off immediately and contact an authorized service center.

Pr ob, indicating that the controller has detected a problem in the temperature measuring circuits and control circuits. Turn the fryer off and contact an authorized service center.



NOTE: This controller is configured for the fryer on which it installed (i.e., gas or electric and full- or split-pot). Although identical in appearance, controllers configured for use on one type of fryer are not interchangeable with those configured for use on another type.

CONTROLLER OPERATING INSTRUCTIONS

1. Turn the controller on by pressing the ON/OFF switch .

The controller software version number will display for four seconds then, *in non-CE units*, the setpoint temperature will appear in the display. *In CE units*, the frypot temperature will appear in the display – to view the setpoint temperature, press the temperature switch  for the frypot in question.

A decimal point will appear between the first two numbers of the display, indicating that the unit is heating. When the frypot has reached the setpoint temperature, the heat indicator decimal point will go out, indicating that the fryer is ready for cooking.

2. Adjust the setpoint if necessary. To raise the setpoint temperature, press an up arrow . Press a down arrow  to lower the setpoint temperature.

The display will change at the rate of approximately one-degree per second initially. If the arrow is pressed and held, after a change of about 12°, the rate of change will increase, allowing large changes in setpoint temperature to be made quickly.

SELECTING FAHRENHEIT OR CELSIUS DISPLAY MODE

To toggle the temperature display between Fahrenheit and Celsius, press the right C/F switch . The display(s) will change from xxx°F to xxx°C, where “xxx” is the frypot or setpoint temperature.

CANCELING THE MELT-CYCLE

 **DANGER**

Do not cancel the melt-cycle mode if using solid shortening!

The melt-cycle is designed to prevent scorching shortening and overheating the frypot or elements while gradually melting blocks of shortening. The controller automatically starts the fryer in the

melt-cycle mode and remains in this mode until the frypot temperature reaches 180°F (82°C) or the melt-cycle is cancelled by the operator. If you are not using solid shortening, you may cancel the melt-cycle.

To cancel the melt-cycle on a full-pot unit, press the right melt-cycle cancel switch . On a split-pot unit, press the left switch for the left frypot or the right switch for the right frypot.

DISABLING OR ENABLING THE MELT-CYCLE CANCEL SWITCH

The controller can be programmed to disable the melt-cycle cancel switch to prevent accidentally canceling the melt-cycle.

1. With the controller in the OFF mode, press the melt-cycle cancel switch . The display will show either "0", meaning that the melt-cycle **can** be bypassed or a "1" meaning that the melt-cycle **cannot** be bypassed.
2. To change the bypass configuration, press and hold the melt-cycle cancel switch for five to six seconds to toggle the "0" to "1" or "1" to "0". Release the switch when the display shows the desired setting.

RE SERIES MARINE E⁴ ELECTRIC FRYERS

CHAPTER 4: FILTRATION INSTRUCTIONS

4.1 Introduction

The FootPrint Pro filtration system allows the oil in one frypot to be safely and efficiently filtered while the other frypots in a battery remain in operation. Section 4.2 covers preparation of the filter system. Operation of the system is covered in section 4.3.

WARNING

The work center supervisor is responsible for ensuring that operators are made aware of the inherent hazards of operating a hot oil filtering system, particularly the aspects of oil filtration, draining and cleaning procedures.

4.2 Preparing the Filter for Use

1. Rotate the pan-locking rod to either side until it clears the filter pan, then pull the pan out from the cabinet. Remove the crumb tray, hold-down ring. Remove the used filter paper in the pan. Remove the filter paper support screen. Clean all components with a solution of detergent and hot water then dry thoroughly.

The filter pan on the is equipped with rollers in rails, much like a kitchen drawer. The pan may be removed for cleaning or to gain access to interior components by lifting the front of the pan to disengage the front rollers, then pulling it forward until the rear rollers clear the rails. The pan cover must not be removed except for cleaning, interior access, or to allow a shortening disposal unit (SDU) to be positioned under the drain.

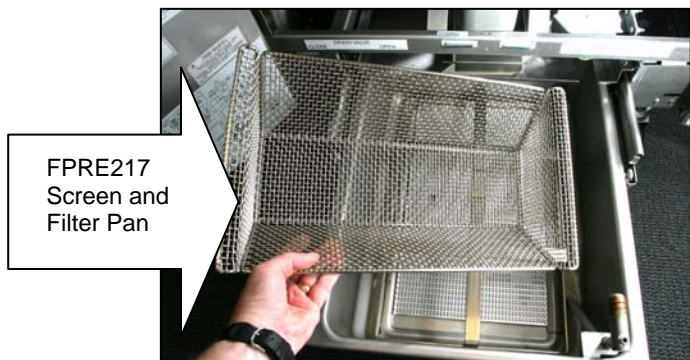
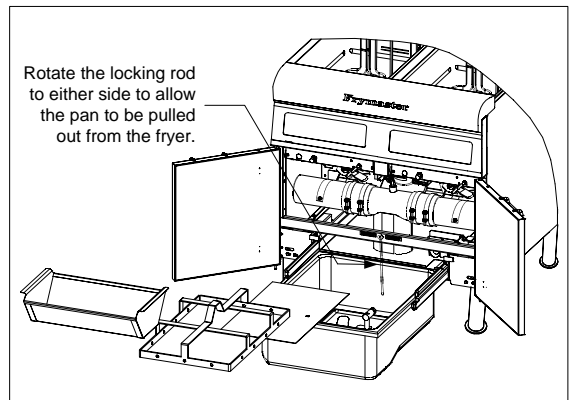

2. Inspect the filter pan connection fitting to ensure that both O-rings are in good condition. The O-rings are located on the tube disconnect inside the filter pan as shown on the drawing down and to the right.
3. Place the metal filter screen in the center of the bottom of the pan, then lay a sheet of filter paper on top of the pan, overlapping on all sides.
4. Position the hold-down ring over the filter paper and lower the ring into the pan, allowing the paper to fold up around the ring as it is lowered to the bottom of the pan.
5. When the hold-down ring is in position, sprinkle one cup of filter powder evenly over the paper.
6. Replace the crumb tray in the filter pan, and then push the filter pan back into the fryer, positioning it under the drain.

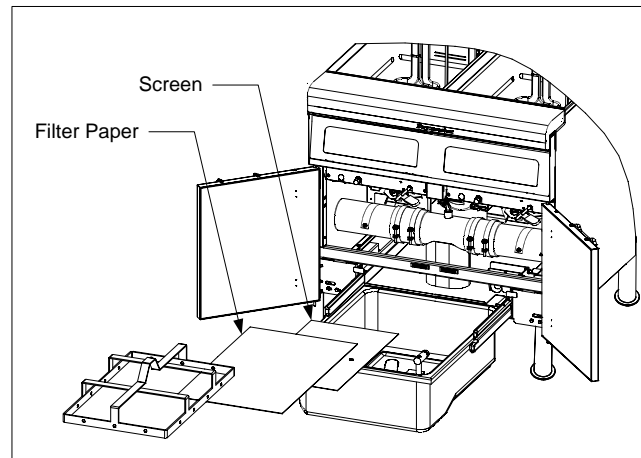
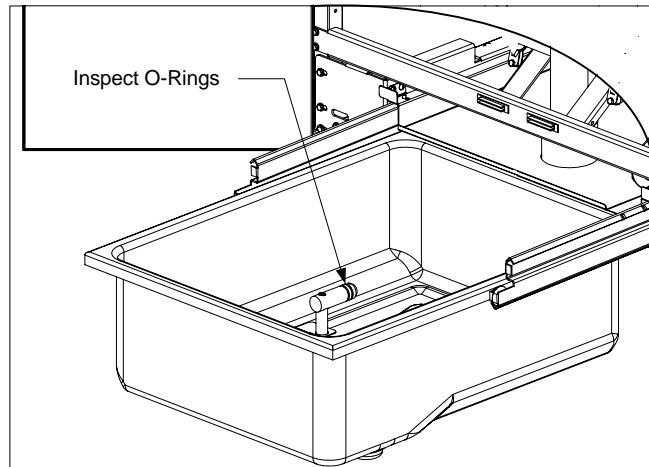

4.3 Operation of the Filter

⚠ DANGER

Draining and filtering of oil must be accomplished with care to avoid the possibility of a serious burn caused by careless handling. The oil to be filtered is at or near 350°F (177°C). Ensure drain handles are in their proper position before operating any switches or valves. Wear all appropriate safety equipment when draining and filtering oil.

⚠ DANGER

NEVER attempt to drain oil from the fryer with the elements energized! Doing so will cause irreparable damage to the elements and may cause a flash fire. Doing so will also void the Frymaster warranty.

1. Ensure that the filter is prepared. See Sec. 4.2
2. Make sure the oil is at operating temperature.

3. Turn the fryer power OFF. Drain the frypot into the filter pan. Remove the basket support rack and raise the element assembly to the up position. If necessary, use the *Fryer's Friend* clean-out rod to clear the drain from **inside** the frypot.



⚠ DANGER

Do not drain more than one frypot at a time into the built-in filtration unit to avoid overflow and spillage of hot oil.

⚠ DANGER

NEVER attempt to clear a clogged drain valve from the front of the valve! Hot oil will rush out creating the potential for severe burns. DO NOT hammer on the drain valve with the cleanout rod or other objects. Damage to the ball inside will result in leaks and will void the Frymaster warranty.

4. After the oil has drained from the frypot, turn the filter handle to the ON position to start the pump and begin the filtering process. Make sure the drain valve is left open. There may be a slight delay before the pump activates.

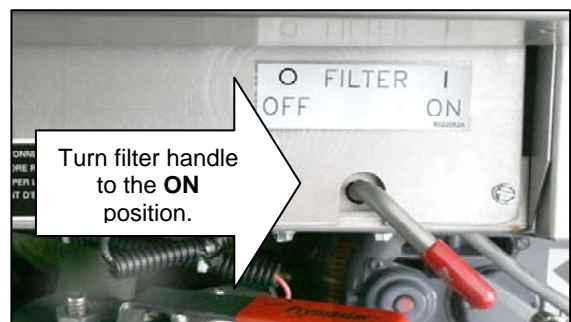

5. The filter pump draws the oil through the filter medium and circulates it through the frypot during a 5-minute process called polishing. Polishing cleans the oil by trapping solid particles in the filter medium.
6. After 5 minutes, close the drain valve and allow the fryer to refill. Let the filter pump run 10 to 12 seconds after the oil begins to bubble. Turn the filter off.

⚠ WARNING

The filter pump is equipped with a manual reset switch (see photo below) in case the filter motor overheats or an electrical fault occurs. If this switch trips, turn OFF power to the filter system and allow the pump motor to cool 20 minutes before attempting to reset the switch.

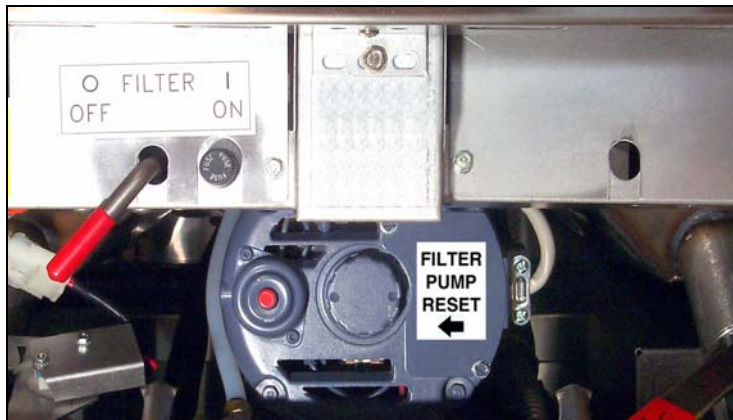

7. Lower the elements into the frypot and reinstall the basket support rack. Ensure the drain valve is fully closed. (If the drain valve is not fully closed, the fryer will not operate.) Turn the fryer ON and allow the oil to reach setpoint.

⚠ DANGER

The crumb tray must be emptied into a fireproof container at the end of frying operations each day. Some food particles can spontaneously combust if left soaking in certain shortening.

⚠ WARNING

Do not bang fry baskets or other utensils on the fryer's joiner strip. The strip is present to seal the joint between the fry vessels. Banging fry baskets on the strip to dislodge shortening will distort the strip, adversely affecting its fit. It is designed for a tight fit and should only be removed for cleaning.

4.4 Draining and Disposing of Waste Oil

When your oil has reached the end of its usable life, drain the oil into an appropriate container for transport to the disposal container. Frymaster recommends the use of the Frymaster Shortening Disposal Unit (SDU). Refer to the documentation furnished with the disposal unit for specific operating instructions. If a shortening disposal unit is not available, allow the oil to cool to 100°F (38°C), and then drain the oil into a metal stockpot or similar metal container. When draining is finished, close the fryer drain valve securely.

 **DANGER**

Allow oil to cool to 100°F (38°C) before draining into an appropriate container for disposal. When draining oil into a disposal unit, do not fill above the maximum fill line located on the container.

RE SERIES MARINE E⁴ ELECTRIC FRYERS

CHAPTER 5: PREVENTIVE MAINTENANCE

5.1 Cleaning the Fryer

 **DANGER**

The crumb tray in fryers equipped with a filter system must be emptied into a fireproof container at the end of frying operations each day. Some food particles can spontaneously combust if left soaking in certain shortening material.

 **DANGER**

Never attempt to clean the fryer during the frying process or when the frypot is filled with hot oil. If water comes in contact with oil heated to frying temperature, it will cause spattering of the oil, which can result in severe burns to nearby personnel.

 **WARNING**

Use a commercial-grade cleaner formulated to effectively clean and sanitize food-contact surfaces. Read the directions for use and precautionary statements before use. Particular attention must be paid to the concentration of cleaner and the length of time the cleaner remains on the food-contact surfaces.

5.1.1 Clean Inside and Outside of the Fryer Cabinet – Daily

Clean inside the fryer cabinet with a dry, clean cloth. Wipe all accessible metal surfaces and components to remove accumulated oil and dust.

DO NOT spray the fryer cabinet with water.

Clean outside the fryer cabinet, with a clean, damp cloth soaked with dishwashing detergent. Wipe with a clean, damp cloth.

5.1.2 Clean the Built-in Filtration System – Daily

 **WARNING**

Never drain water into the filter pan. Water will damage the filter pump.

There are no periodic preventive maintenance checks and services required for the FootPrint Pro Filtration System other than daily cleaning of the filter pan and associated components with a solution of hot water and detergent.

 **WARNING**

Never spray the fryer with water or use water jets to clean this equipment.

5.1.3 Clean the Frypot and Heating Elements – Weekly

 DANGER

Never operate the appliance with an empty frypot. The frypot must be filled with water or oil/shortening before energizing the elements. Failure to do so will result in irreparable damage to the elements and may cause a fire.

Boiling Out the Frypot using Digital Controllers (For other controllers see the Frymaster Controller Manual PN 819-5916.)

Before the fryer is first used, it should be boiled out to ensure that residue from the manufacturing process has been eliminated. Also, after the fryer has been in use for a period of time, a hard film of caramelized vegetable oil will form on the inside of the frypot. This film should be periodically removed by following the boil-out procedure that follows.

1. Before switching the fryer(s) ON, close the frypot drain valve(s), then fill the empty frypot with a mixture of cold water and low-sudsing dishwashing detergent (or a commercially available boil-out solution). Follow instructions on the container when mixing.
2. Press the fryer ON/OFF switch to the ON position.
3. Set the temperature to 190°F (88°C).
4. Simmer the solution for 45 minutes to one hour. Do not allow the water level to drop below the bottom oil-level line in the frypot during the boil-out operation.

 DANGER

Never leave the fryer unattended during the boil-out process. If the boil-out solution boils over, turn the fryer off immediately and let the solution cool for a few minutes before resuming the process.

5. Turn the fryer ON/OFF switch(s) to the OFF position.
6. Add two gallons of water. Drain out the solution into a stockpot and clean the frypot(s) thoroughly.

 WARNING

Do not drain boil-out solution into a shortening disposal unit, a built-in filtration unit, or a portable filter unit. These units are not intended for this purpose, and will be damaged by the solution.

7. Refill the frypot(s) with clean water. Rinse the frypot(s) twice, drain and dry with a clean towel. Thoroughly remove all water from the frypot and elements before refilling the frypot with oil.

⚠ DANGER

Remove all drops of water from the frypot before filling with oil or shortening. Failure to do so will cause spattering of hot liquid when the oil or shortening is heated to cooking temperature.

5.1.4 Clean Detachable Parts and Accessories – Weekly

Wipe all detachable parts and accessories with a clean, dry cloth. Use a clean cloth saturated with detergent to remove accumulated carbonized oil on detachable parts and accessories. Rinse the parts and accessories thoroughly with clean water and wipe dry before reinstalling.

5.2 Annual/Periodic System Inspection

This appliance should be inspected and adjusted periodically by qualified service personnel as part of the galley material maintenance management (3M) program.

Frymaster recommends that a Factory Authorized Servicer inspect this appliance at least annually as follows:

Fryer

- Inspect the cabinet inside and out, front and rear for excessive oil.
- Verify that the heating element wires are in good condition and that leads have no visible fraying or insulation damage and that they are free of oil.
- Verify that heating elements are in good condition with no carbon/caramelized oil build-up. Inspect the elements for signs of extensive dry-firing.
- Verify that the tilt mechanism is working properly when lifting and lowering elements and that the element wires are not binding and/or chafing.
- Verify the heating-element amp-draw is within the allowed range as indicated on the appliance's rating plate.
- Verify that the temperature and high-limit probes are properly connected, tightened and functioning properly, and that mounting hardware and probe guards are present and properly installed.
- Verify that component box and contactor box components (i.e. controller, relays, interface boards, transformers, contactors, etc.) are in good condition and free from oil and other debris.
- Verify that component box and contactor box wiring connections are tight and that wiring is in good condition.
- Verify that all safety features (i.e. contactor shields, drain safety switches, hood shunts, reset switches, etc.) are present and functioning properly.

- Verify that the frypot is in good condition and free of leaks and that the frypot insulation is in serviceable condition.
- Verify that all wiring harnesses and wiring connections are tight and in good condition.

Built-In Filtration System

- Inspect all oil-return and drain lines for leaks and verify that all connections are tight.
- Inspect the filter pan for leaks and cleanliness. If there is a large accumulation of crumbs in the crumb basket, instruct the supervisor that the crumb basket must be emptied into a fireproof container and cleaned daily.
- Verify that all O-rings and seals (including those on quick-disconnect fittings) are present and in good condition. Replace O-rings and seals if worn or damaged.
- Check filtration system integrity as follows:
- Verify that filter pan cover is present and properly installed.
- With the filter pan empty, place each oil return handle, one at a time, in the ON position. Verify that the pump activates and that bubbles appear in the cooking oil of the associated frypot.
- Close all oil return valves (i.e., place all oil return handles in the OFF position). Verify proper functioning of each oil return valve by activating the filter pump using the lever on one of the oil return handle microswitches. No air bubbles should be visible in any frypot.
- Verify that the filter pan is properly prepared for filtering, then drain a frypot of oil heated to 350°F into the filter pan and close the frypot drain valve. Place the oil return handle in the ON position. Allow all oil to return to the frypot (indicated by bubbles in the oil). Return the oil return handle to the OFF position. The frypot should have refilled in no more than 2 minutes and 30 seconds.

RE SERIES MARINE E⁴ ELECTRIC FRYERS

CHAPTER 6: OPERATOR TROUBLESHOOTING

6.1 Introduction

This section provides an easy reference guide to some of the common problems that may occur during the operation of this equipment. The troubleshooting guides that follow are intended to help correct, or at least accurately diagnose, problems with this equipment. Although the chapter covers the most common problems reported, you may encounter problems that are not covered. In such instances, the Frymaster Technical Services staff will make every effort to help you identify and resolve the problem.

When troubleshooting a problem, always use a process of elimination starting with the simplest solution and working through to the most complex. Never overlook the obvious – anyone can forget to plug in a cord or fail to close a valve completely. Most importantly, always try to establish a clear idea of why a problem has occurred. Part of any corrective action involves taking steps to ensure that it doesn't happen again. If a controller malfunctions because of a poor connection, check all other connections, too. If a fuse continues to blow, find out why. Always keep in mind that failure of a small component may often be indicative of potential failure or incorrect functioning of a more important component or system.

Before calling a service agent or the Frymaster HOTLINE (1-800-551-8633) or contacting via e-mail at service@frymaster.com:

- **Verify that electrical cords are plugged in and that circuit breakers are on.**
- **Verify that frypot drain valves are fully closed.**

 **DANGER**

Hot oil will cause severe burns. Never attempt to move this appliance when filled with hot oil or to transfer hot oil from one container to another.

 **DANGER**

This equipment should be disconnected from the electrical power supply when servicing, except when electrical circuit tests are required. Use extreme care when performing such tests.

This appliance may have more than one electrical power supply connection point. Disconnect all power cords before servicing.

Inspection, testing, and repair of electrical components should be performed by authorized personnel only.

6.2 Troubleshooting

6.2.1 Control and Heating Problems

Problem	Probable Causes	Corrective Action
Controller won't activate.	A. Power cord is not plugged in or circuit breaker is tripped.	A. Plug power cord in and verify that circuit breaker is not tripped.
	B. Controller has failed.	B. If available, substitute a controller known to be working for the suspect controller. If the substitute controller functions correctly, order a new controller.
	C. Power supply component or interface board has failed.	C. If any of the components in the power supply system (including the transformer and interface board) fail, power will not be supplied to the controller and it will not function. Determining which component has failed is beyond the scope of operator troubleshooting. Call FAS.
Fryer does not heat or heat after filtering.	A. Drain valve is open.	A. This fryer is equipped with a drain safety switch that prevents the heating element from being energized if the drain valve is not fully closed. Verify that the drain valve is fully closed.
	B. Controller has failed.	B. If available, substitute a controller known to be working for the suspect controller. If the substitute controller functions correctly, order a new controller.
	C. One or more other components have failed.	C. If the circuitry in the fryer control system cannot determine the frypot temperature, the system will not allow the element to be energized or will de-energize the element if it is already energized. If the contactor, element, or associated wiring fails, the element will not energize. Determining which specific component is malfunctioning is beyond the scope of operator troubleshooting. Call FAS.

Problem	Probable Causes	Corrective Action
<p>Fryer repeatedly cycles on and off when first started.</p>	<p>Fryer is in melt-cycle mode.</p>	<p>This is normal. The standard operational mode for the controller is for the elements to cycle on and off until the temperature in the frypot reaches 180°F (82°C). The purpose of the melt-cycle is to allow controlled melting of solid shortening to prevent scorching and flash fires or damage to the element.</p>
<p>Fryer heats until high limit trips with heat indicator ON.</p>	<p>Temperature probe or controller has failed.</p>	<p>If available, substitute a controller known to be working for the suspect controller. If the substitute controller functions correctly, order a new controller. If substitution of the controller does not resolve the problem, the most likely cause is a failed temperature probe.</p>
<p>Fryer heats until high limit trips without heat indicator ON.</p>	<p>Contact or controller has failed.</p>	<p>If available, substitute a controller known to be working for the suspect controller. If the substitute controller functions correctly, order a new controller. If substitution of the controller does not resolve the problem, the most likely cause is a contactor failed in the closed position.</p>
<p>Fryer stops heating with heat indicator ON.</p>	<p>The high limit thermostat or contactor has failed.</p>	<p>The fact that the heat indicator is ON indicates that the controller is functioning properly and is calling for heat. The hi-limit thermostat functions as a normally closed switch. If the thermostat fails, the "switch" opens and power to the elements is shut off. If the contactor fails to close, no power is supplied to the elements. Determining which component has failed is beyond the scope of operator troubleshooting. Call FAS.</p>

6.2.2 Filtration Problems

Problem	Probable Causes	Corrective Action
<p>Filter pump won't start.</p>	<p>A. Power cord is not plugged in or circuit breaker is tripped.</p>	<p>A. Verify that the power cord is fully plugged in. If so, verify that circuit breaker is not tripped.</p>
	<p>B. Pump motor has overheated causing the thermal overload switch to trip.</p>	<p>B. If the motor is too hot to touch for more than a few seconds, the thermal overload switch has probably tripped. Allow the motor to cool at least 20 minutes then press the Pump Reset Switch.</p>
	<p>C. Blockage in filter pump.</p> <p>Test: Close the drain valve and pull the filter pan out from the fryer. Activate the pump. If the pump motor hums for a short time then stops, the probable cause is blockage of the pump itself.</p>	<p>C. Pump blockages are usually caused by sediment buildup in the pump due to improperly sized or installed filter paper and failure to use the crumb screen.</p>
<p>Filter pump runs but oil does not return to frypot and there is no bubbling oil.</p>	<p>Blockage in filter pan suction tube.</p> <p>Test: Close the drain valve and pull the filter pan out from the fryer. Activate the pump. If the air or bubbling oil occurs, there is a blockage in the filter pan suction tube.</p>	<p>The blockage may be caused by sediment buildup or, if solid shortening is used, solidified shortening in the tube. Use a thin, flexible wire to remove the blockage.</p>
<p>Filter pump runs, but oil return is very slow and bubbling oil occurs.</p>	<p>A. Improperly installed filter pan components.</p>	<p>A. Verify that filter screen is in bottom of pan with paper top of screen.</p> <p>Verify that O-rings are present and in good condition on filter pan connection fitting.</p>

(continued on the following page)

Problem	Probable Causes	Corrective Action
<p>Filter pump runs, but oil return is very slow and bubbling oil occurs.</p>	<p>B. Attempting to filter with oil or shortening that is not hot enough.</p>	<p>B. In order to properly filter, the oil or shortening should be at or near 350°F (177°C). At temperatures lower than this, the oil becomes too thick to pass through the filter medium easily, resulting in much slower oil return and eventual overheating of the filter pump motor. Make sure oil is at or near frying temperature before draining oil into filter pan.</p>

RE SERIES MARINE E⁴ ELECTRIC FRYERS

CHAPTER 7: SERVICE PROCEDURES

7.1 General

Before performing any maintenance on this equipment, disconnect the fryer from the electrical power supply.

When electrical wires are disconnected, it is recommended that they be marked in such a way as to facilitate re-assembly.

7.2 Replacing a Remote Digital Controller

1. Unplug all power cords.
2. Unplug the 15-pin connector from the back of the controller.
3. Remove the mounting screws.
4. Reassemble in reverse order to complete the replacement and return the fryer to service.

7.3 Replacing Component Box Components

1. Disconnect the fryer from the electrical power supply.
2. The front panel bezel is held in place by tabs at the top and bottom. Slide the metal bezel up to disengage the lower tabs. Then slide the bezel down to disengage the upper tabs.
3. Remove the two screws from the upper corners of the front panel bezel and allow the front panel bezel to swing down.
4. Remove the front panel bezel assembly by lifting it from the hinge slots in the panel bezel frame.
5. Disconnect the wiring from the component to be replaced, being sure to make a note of where each wire was connected.
6. Dismount the component to be replaced and install the new component, being sure that any required spacers, insulation, washers, etc. are in place.

NOTE: If more room to work is required, the control panel frame assembly may be removed by removing the hex head screws that secure it to the fryer cabinet (see illustration on the following page). If this option is chosen, all front panel assemblies must be removed per steps 2-4 above. The cover plate on the lower front of the component box may also be removed if desired. *Removing the component box itself from the fryer is not recommended due to the difficulty involved in disconnecting and reconnecting the oil-return valve rods, which pass through openings in the component box.*

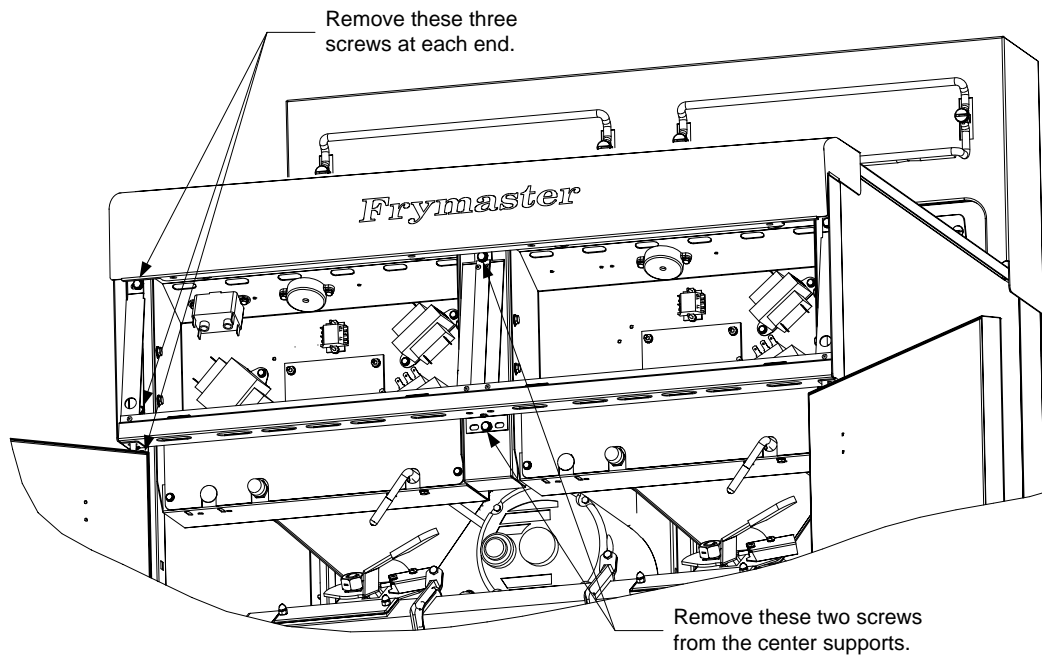

Removing the Control Panel Frame and Top Cap Assembly

7. Reconnect the wiring disconnected in Step 5, referring to your notes and the wiring diagrams on the fryer door to ensure that the connections are properly made. Also, verify that no other wiring was disconnected accidentally during the replacement process.
8. Reverse steps 1-4 to complete the replacement and return the fryer to service.

7.4 Replacing a High-Limit Thermostat

1. Remove the filter pan and lid from the unit. Drain the frypots into a Shortening Disposal Unit (SDU) or other appropriate metal container.



DO NOT drain more than one full frypot or two split frypots into the SDU at one time.

2. Disconnect the fryer from the electrical power supply and reposition it to gain access to the rear of the fryer.
3. Remove the four screws from both the left and right sides of the lower back panel.
4. Locate the high-limit that is being replaced and follow the two-black wires to the 12-pin connector C-6. Note where the leads are connected prior to removing them from the connector. Unplug the 12-pin connector C-6 and using a pin-pusher push the pins of the high-limit out of the connector.
5. Using a wrench, carefully unscrew the high-limit thermostat to be replaced.
6. Apply Loctite™ PST 567 or equivalent sealant to the threads of the replacement and screw it securely into the frypot.

7. Insert the leads into the 12-pin connector C-6 (see illustration below). For full-vat units or the left half of a dual-vat unit (as viewed from the rear of the fryer) the leads go into positions 1 and 2 of the connector. For the right half of a dual-vat unit (as viewed from the rear of the fryer), the leads go into positions 7 and 8. In either case, polarity does not matter.

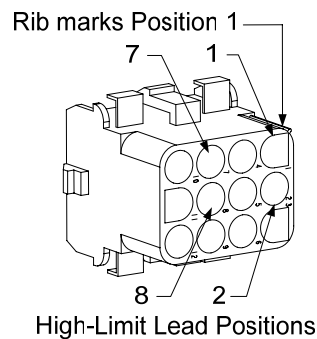

8. Reconnect the 12-pin connecting plug C-6. Use wire ties to secure any loose wires.
9. Reinstall the back panels reposition the fryer under the exhaust hood, and reconnect it to the electrical power supply to return the fryer to service.

7.5 Replacing a Temperature Probe

1. Remove the filter pan and lid from the unit. Drain the frypots into a Shortening Disposal Unit (SDU) or other appropriate metal container.

⚠ DANGER

DO NOT drain more than one full frypot or two split frypots into the SDU at one time.

2. Disconnect the fryer from the electrical power supply and reposition it to gain access to the rear of the fryer.
3. Remove the four screws from both sides of the lower back panel. Then remove the two screws on both the left and right sides of the back of the tilt housing. Lift the tilt housing straight up to remove from the fryer.
4. Locate the red and white wires of the temperature probe to be replaced. Note where the leads are connected prior to removing them from the connector. Unplug the 12-pin connector C-6 and using a pin-pusher push the pins of the temperature probe out of the connector.

5. Raise the element and remove the securing probe bracket and metal tie wraps that secure the probe to the element (see illustration below).

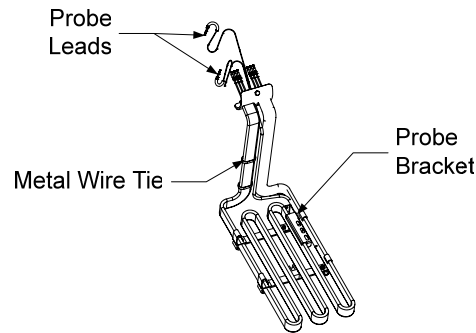

6. Gently pull on the temperature probe and grommet. Pulling the wires up the rear of the fryer and through the element tube assembly.
7. Insert the replacement temperature probe (wires first) into the tube assembly ensuring that the grommet is in place. Secure the probe to the elements using the bracket which was removed in Step 5 and the metal tie wraps which were included in the replacement kit.
8. Route the probe wires out of the tube assembly following the element wires down the back of the fryer through the Heyco bushings to the 12-pin connector C-6. Secure the wires to the sheathing with wire ties ensuring that the metal sheathing is secured with grounding clip .
9. Insert the temperature probe leads into the 12-pin connector C-6 (see illustration below). For full-vat units or the right half of a dual-vat unit (as viewed from the rear of the fryer) the red lead goes into position 3 and the white lead into position 4 of the connector. For the left half of a dual-vat unit (as viewed from the rear of the fryer), the red lead goes into position 9 and the white lead into position 10. **NOTE: *Right* and *left*** refer to the fryer as viewed from the rear.

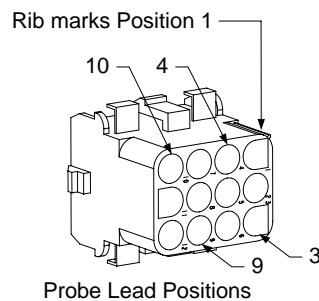

10. Secure any loose wires with wire ties making sure that the lead wires will not interfere with the movement of the springs. Rotate the elements up and down making sure that movement is not restricted and that the wires are not pinched.
11. Reinstall the tilt housing and back panels, reposition the fryer under the exhaust hood, and reconnect it to the electrical power supply to return the fryer to service.

7.6 Replacing a Heating Element

1. Perform steps 1-3 of section 7.5, *Replacing a Temperature Probe*.

2. On dual-vat fryers, and on full-vat fryers where the temperature probe is attached to the element being replaced, disconnect the wire harness containing the probe wiring. Using a pin pusher, disconnect the probe wires from the 12-pin connector C-6.
3. In the rear of the fryer directly behind the frypot disconnect the 6-pin connector for the left element (as viewed from the front of the fryer) or the 9-pin connector for the right element. Press in on the tabs on each side of the connector while pulling outward on the free end to extend the connector and release the element leads (see photo below). Pull the leads out of the connector and out of the wire sleeving.

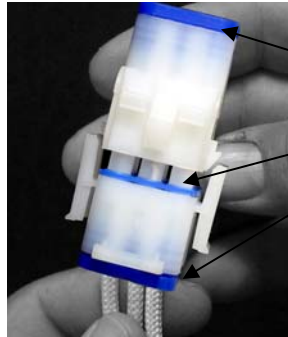

Note: Liquid resistant seals.

4. Raise the element to the full up position and support the elements.
5. Remove the hex head screws and nuts that secure the element to the tube assembly and pull the element out of the frypot. **NOTE:** Full-vat elements consist of two dual-vat elements clamped together. For full-vat units, remove the element clamps before removing the nuts and screws that secure the element to the tube assembly.
6. If applicable, recover the probe bracket and probe from the element being replaced and install them on the replacement element, then install the replacement element in the frypot, securing it with the nuts and screws removed in Step 5 to the tube assembly ensuring the gasket is between the tube and element assembly.
7. Route the element leads through the element tube assembly and into the wire sleeving to prevent chafing. Ensure that the wire sleeving is routed back through the Heyco bushing keeping it clear from the lift springs. Also ensure that the wire sleeving extends into the tube assembly to protect the edge of the tube assembly from chafing the wires. Press the pins into the connector in accordance with the diagram below, and then close the connector to lock the leads in place. **NOTE:** It is critical that the wires be routed through the sleeving to prevent chafing.

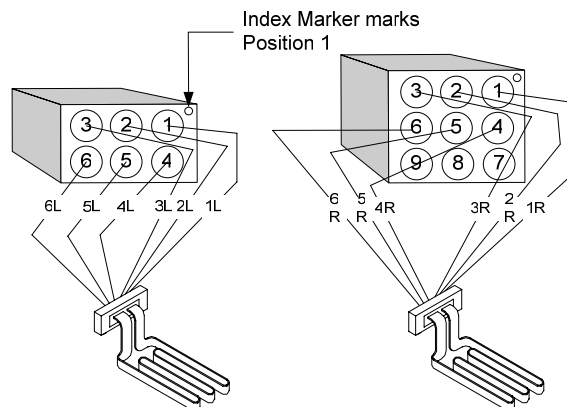

8. Reconnect the element connector it was removed from directly behind the frypot, ensuring that the latches lock.
9. Insert the temperature probe leads into the 12-pin wiring harness connector C-6 (see illustration below). For full-vat units or the right half of a dual-vat unit, the red lead goes into position 3 and the white into position 4. For the left half of a dual-vat unit, the red lead goes into position 9 and the white into position 10. **NOTE: *Right* and *left* refer to the fryer as viewed from the rear.**

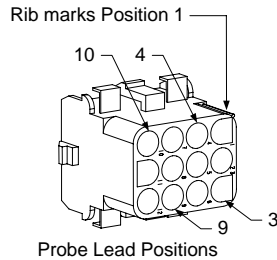

10. Reconnect the 12-pin connector C-6 of the wiring harness disconnected in Step 2.
11. Lower the element down onto the basket rack.
12. Reinstall the tilt housing and back panels, reposition the fryer under the exhaust hood, and reconnect it to the electrical power supply.

7.7 Replacing Contactor Box Components

1. If replacing a contactor box component above the built-in filter system, remove the filter pan and lid from the unit. Drain the frypots into a Shortening Disposal Unit (SDU) or other appropriate metal container. If replacing a contactor box component in a non-filter unit or a frypot that's not over the filter pan, drain the frypot above the box into a Shortening Disposal Unit (SDU) or other appropriate metal container.



DO NOT drain more than one full frypot or two split frypots into the SDU at one time.

2. Disconnect the fryer from the electrical power supply.
3. Remove the two screws securing the cover of the contactor box. The contactor boxes above the filter pan are accessed by sliding under the fryer. They are located to the left and right above the guide rails (see photo below). The contactor boxes of non-filter units or frypots not over the filter pan are accessed by opening the fryer door directly under the affected frypot.

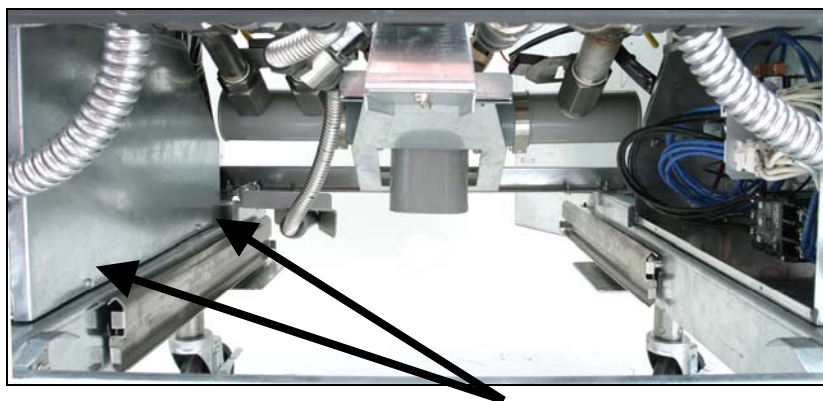

Remove two screws to access contactor box components above the filter pan.

4. The contactors and relays are held on by threaded pin studs so that only removal of the nut is required to replace the component.
5. After performing necessary service, reverse steps 1-4 to return the fryer to operation.

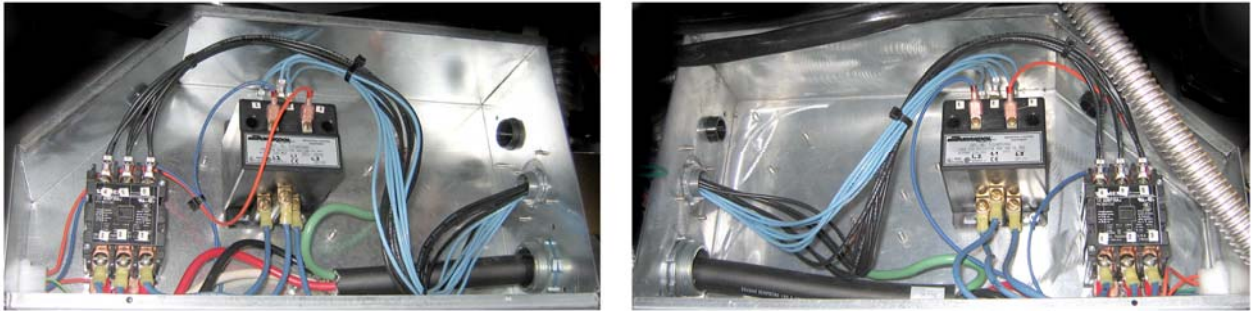

Left and right views of mechanical contactor box components.

7.8 Replacing a Frypot

1. Drain the frypot into the filter pan or, if replacing a frypot over the filter system, into a Shortening Disposal Unit (SDU) or other appropriate metal container. If replacing a frypot over the filter system, remove the filter pan and lid from the unit.

DANGER

DO NOT drain more than one full frypot or two split frypots into the SDU at one time.

2. Disconnect the fryer from the electrical power supply and reposition it to gain access to both the front and rear.
3. Slide the metal bezel up to release the bottom tabs, then slide the bezel down to disengage the upper tabs.
4. Remove the two screws from the upper corners of the control panels and allow them to swing down (see illustration and photo on page 1-1).
5. Unplug the wiring harnesses and ground wires from the backs of the controllers. Remove the controllers by lifting them from the hinge slots in the control panel frame.
6. Remove the tilt housing and back panels from the fryer. The tilt housing must be removed first in order to remove the upper back panel.
7. To remove the tilt housing remove the hex head screws from the rear edge of the housing. The housing can be lifted straight up and off the fryer.
8. Remove the control panel by removing the screw in the center and the nuts on both sides.
9. Loosen the component boxes by removing the screws, which secure them in the cabinet.
10. Dismount the top cap by removing the nuts at each end that secure it to the cabinetry.
11. Remove the hex head screw that secures the front of the frypot to the cabinet cross brace.

12. Remove the top-connecting strip that covers the joint with the adjacent frypot.
13. Unscrew the Teflon vent/vacuum-breaker tube fitting, unscrew the nut located on the front of each section of drain tube, and remove the tube assembly from the fryer.
14. Remove the covers from the drain safety switch(es) and disconnect the switch wiring at the switch(es).
15. At the rear of the fryer, unplug the 12-pin connector C-6 and, using a pin pusher, disconnect the high-limit thermostat leads.
16. Disconnect the oil return flexline(s) at the frypot end(s).
17. Raise the elements to the “up” position and disconnect the element springs.
18. Remove the machine screws and nuts that secure the element tube assembly to the frypot. Carefully lift the element assembly from the frypot and secure it to the cross brace on the rear of the fryer with wire ties or tape.
19. Carefully lift the frypot from the fryer and place it upside down on a stable work surface.
20. Recover the drain valve(s), oil return flexline connection fitting(s), and high-limit thermostat(s) from the frypot. Clean threads and apply Loctite™ PST 567 or equivalent sealant to the threads of the recovered parts and install them in the replacement frypot.
21. Carefully lower the replacement frypot into the fryer. Reinstall the hex head screw removed in step 7 to attach the frypot to the fryer.
22. Position the element tube assembly in the frypot and reinstall the machine screws and nuts removed in step 14.
23. Reconnect the oil return flexlines to the frypot, and replace aluminum tape, if necessary, to secure heater strips to the flexlines.
24. Insert the high-limit thermostat leads disconnected in step 13 (see illustration on page 1-3 for pin positions).
25. Reconnect the drain safety switch wiring to the switch(es) in accordance with the diagram below then reinstall the switch covers.

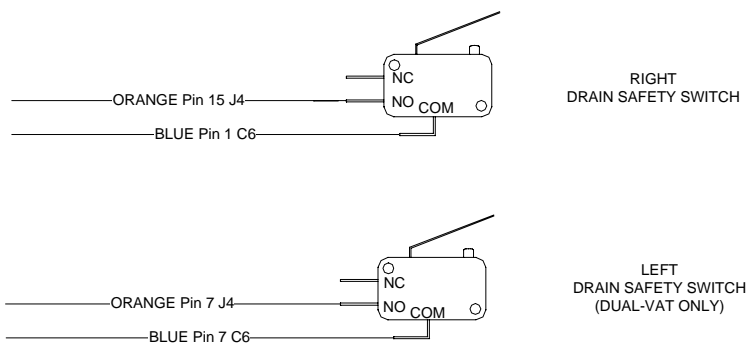

26. Reinstall the drain tube assembly.

27. Reinstall the top connecting strips, top cap, control box and panel, tilt housing and back panels.
28. Reinstall controllers in the control panel frame and reconnect the wiring harnesses and ground wires.
29. Reposition the fryer under the exhaust hood and reconnect it to the electrical power supply.

7.9 Built-in Filtration System Service Procedures

7.9.1 Filtration System Problem Resolution

One of the most common causes of filtration problems is placing the filter paper on the bottom of the filter pan rather than over the filter screen.

⚠ CAUTION
Ensure that filter screen is in place prior to filter paper placement and filter pump operation. Improper screen placement is the primary cause of filtration system malfunction.

Whenever the complaint is “the pump is running, but no oil is being filtered,” check the installation of the filter paper, and ensure that the correct size is being used. While you are checking the filter paper, verify that the O-ring on the bottom of the filter pan is present and in good condition. A missing or worn O-ring allows the pump to take in air and decreases its efficiency. Also, oil leaks on the floor each time a vat is drained.

If the pump motor overheats, the thermal overload will trip and the motor will not start until it is reset. If the pump motor does not start, press the red reset switch (button) located on the rear of the motor.

If the pump starts after resetting the thermal overload switch, then something is causing the motor to overheat. A major cause of overheating is when several frypots are filtered sequentially, overheating the pump and motor. Allow the pump motor to cool at least 30 minutes before resuming operation. Pump overheating can be caused by:

- Solidified shortening in the pan or filter lines, or
- Attempting to filter unheated oil (cold oil is more viscous, overloading the pump motor and causing it to overheat).

If the motor runs but the pump does not, there is a blockage in the pump. Incorrectly sized or installed paper/pads will allow food particles and sediment to pass through the filter pan and into the pump. When sediment enters the pump, the gears bind, causing the motor to overload, again tripping the thermal overload. Shortening that has solidified in the pump will also cause it to seize, with the same result.

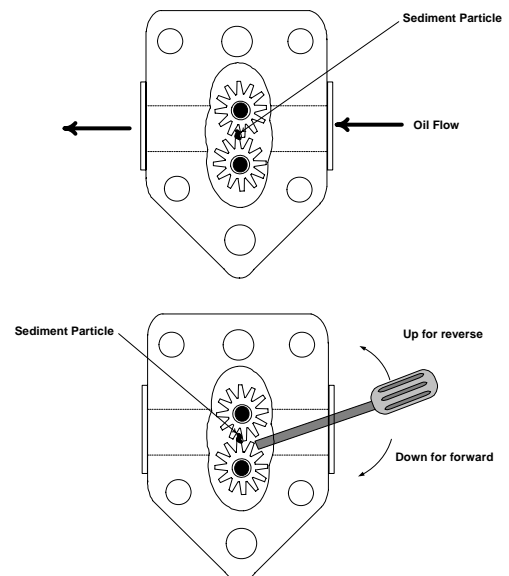

A pump seized by debris or hard shortening can usually be freed by manually moving the gears with a screwdriver or other instrument.

Disconnect power to the filter system, remove the input plumbing from the pump, and use a screwdriver to manually turn the gears.

- Turning the pump gears in reverse will release a hard particle.
- Turning the pump gears forward will push softer objects and solid shortening through the pump and allow free movement of the gears.

Incorrectly sized or installed paper/pads will also allow food particles and sediment to pass through and clog the suction tube on the bottom of the filter pan. Particles large enough to block the suction tube may indicate that the crumb tray is not being used. Pan blockage can also occur if shortening is left in the pan and allowed to solidify. Blockage removal can be accomplished by forcing the item out with an auger or drain snake. Compressed air or other pressurized gases should not be used to force out the blockage.

7.9.2 Replacing the Filter Motor, Filter Pump and Related Components

1. Remove the filter pan and lid from the unit. Drain the frypots into a Shortening Disposal Unit (SDU) or other appropriate metal container.

⚠ DANGER

DO NOT drain more than one full frypot or two split frypots into the SDU at one time.

2. Disconnect the fryer from the electrical power supply and reposition it to gain access to both the front and rear.
3. Disconnect the two flexlines running to the oil-return manifold at the rear of the fryer as well as the pump suction flexline at the end of the filter pan connection (see photo below).



Disconnect flexlines indicated by the arrows.

4. Loosen the nut and bolt that secures the bridge to the oil-return manifold.
5. Remove the cover plate from the front of the motor and disconnect the motor wires.
6. Unplug the pump motor assembly 6-pin connector C-2 and, using a pin pusher, disconnect the vent vacuum-breaker solenoid (pins 2 and 5) that is attached to the oil return manifold.
7. Remove the two nuts and bolts that secure the front of the bridge to the cross brace and carefully slide the bridge rearward off the cross brace until its front end can be lowered to the floor. Undo the single nut holding it in place in back. Be careful not to let the rear of the bridge slip off the manifold at this point.
8. Get a good grip on the bridge, carefully pull it forward off the oil-return manifold, and lower the entire assembly to the floor. Once on the floor, pull the assembly out the front of the fryer.
9. When required service has been completed, reverse steps 6-12 to reinstall the bridge. **NOTE:** The black motor wires go on the top terminal, the white on the bottom. The pump solenoid valve wires go in positions 1 and 4 of the 6-pin connector C-2; the vent vacuum-breaker solenoid valve wires go in positions 2 and 5; the red/black heater tape wires go into position 3 and the violet/white wires go into position 6 (see illustration below).

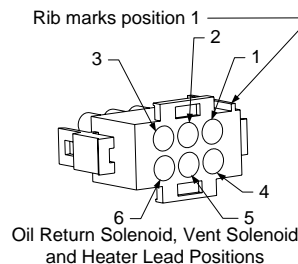

10. Reconnect the unit to the electrical power supply, and verify that the pump is functioning correctly (i.e., when a filter handle is placed in the ON position, the motor should start and there should be strong suction at the intake fitting and outflow at the rear flush port.)
11. When proper operation has been verified, reinstall the back panels and the filter pan and lid.
12. Reposition the fryer under the exhaust hood and reconnect it to the electrical power supply to return the fryer to service.

7.9.3 Replacing the Filter Transformer or Filter Relay

Remove the left controller from the fryer to expose the interior of the left component box. The filter transformer and relay are located as shown in the illustration below. **NOTE:** The right component box is identical to the left except that the filter transformer and relay are not present.

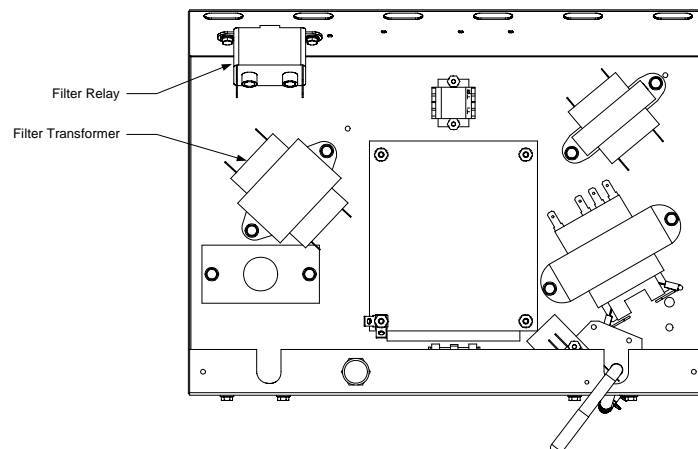

7.10 Interface Board Diagnostic Chart

The following diagram and charts provide ten quick system checks that can be performed using only a multimeter.

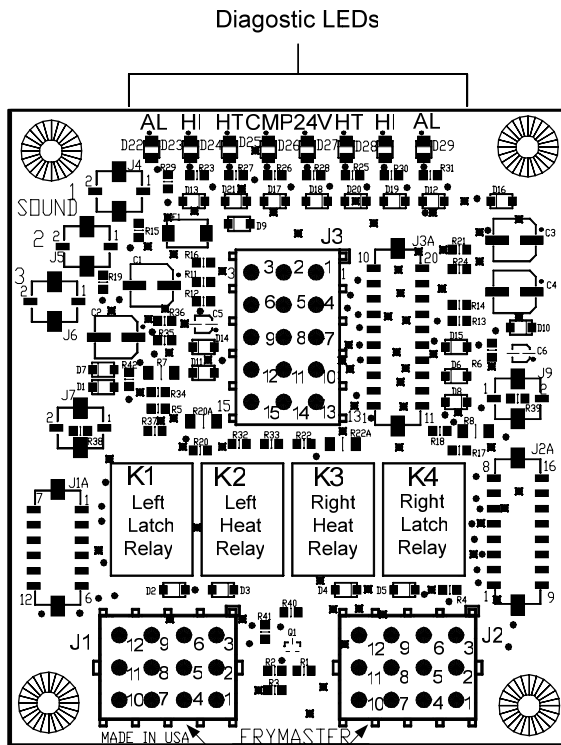

PN 106-6811

Test Points
J1 Left J2 Right

Diagnostic LED Legend	
CMP	indicates power from 12V transformer
24	indicates power from 24V transformer
HI (RH)	indicates output (closed) from right latch relay
HI (LH)	indicates output (closed) from left latch relay
HT (RH)	indicates output from right heat relay
HT (LH)	indicates output from left heat relay
AL (RH)	indicates output (open) from right latch relay
AL (LH)	indicates output (open) from left latch relay

NOTE – When testing the test points on J1 and J2 test use the illustration above depicting the location of Pin 1. Pin 1 is located in the bottom right corner of Both J1 and J2. These test points are ONLY for RE Series boards with J1 and J2 plugs on the front of the board.

Meter Setting	Test	Pin	Pin	Results
12 VAC Power	50 VAC Scale	3 of J2	1 of J2	12-16 VAC
24 VAC Power	50 VAC Scale	2 of J2	Chassis	24-30 VAC
*Probe Resistance (RH)	R X 1000 OHMS	11 of J2	10 of J2	See Chart
*Probe Resistance (LH)	R X 1000 OHMS	1 of J1	2 of J1	See Chart
High-Limit Continuity (RH)	R X 1 OHMS	9 of J2	6 of J2	0 - OHMS
High-Limit Continuity (LH)	R X 1 OHMS	6 of J1	9 of J1	0 - OHMS
Latch Contactor Coil (RH)	R X 1 OHMS	8 of J2	Chassis	3-10 OHMS
Latch Contactor Coil (LH)	R X 1 OHMS	5 of J1	Chassis	3-10 OHMS
Heat Contactor Coil (RH)	R X 1 OHMS	7 of J2	Chassis	18-25 OHMS
Heat Contactor Coil (LH)	R X 1 OHMS	4 of J1	Chassis	18-25 OHMS

* **Disconnect 15-Pin harness from the computer/controller before testing the probe circuit.**

7.11 Probe Resistance Chart

<h3 style="text-align: center;">Probe Resistance Chart</h3> <p style="text-align: center;"><i>For use with fryers manufactured with Minco Thermistor probes only.</i></p>																	
F	OHMS	C	F	OHMS	C	F	OHMS	C	F	OHMS	C	F	OHMS	C			
60	1059	16	130	1204	54	200	1350	93	270	1493	132	340	1634	171			
65	1070	18	135	1216	57	205	1361	96	275	1503	135	345	1644	174			
70	1080	21	140	1226	60	210	1371	99	280	1514	138	350	1654	177			
75	1091	24	145	1237	63	215	1381	102	285	1524	141	355	1664	179			
80	1101	27	150	1247	66	220	1391	104	290	1534	143	360	1674	182			
85	1112	29	155	1258	68	225	1402	107	295	1544	146	365	1684	185			
90	1122	32	160	1268	71	230	1412	110	300	1554	149	370	1694	188			
95	1133	35	165	1278	74	235	1422	113	305	1564	152	375	1704	191			
100	1143	38	170	1289	77	240	1432	116	310	1574	154	380	1714	193			
105	1154	41	175	1299	79	245	1442	118	315	1584	157	385	1724	196			
110	1164	43	180	1309	82	250	1453	121	320	1594	160	390	1734	199			
115	1174	46	185	1320	85	255	1463	124	325	1604	163	395	1744	202			
120	1185	49	190	1330	88	260	1473	127	330	1614	166	400	1754	204			
125	1195	52	195	1340	91	265	1483	129	335	1624	168	405	1764	207			

7.12 Wiring Diagram, Simplified RE17

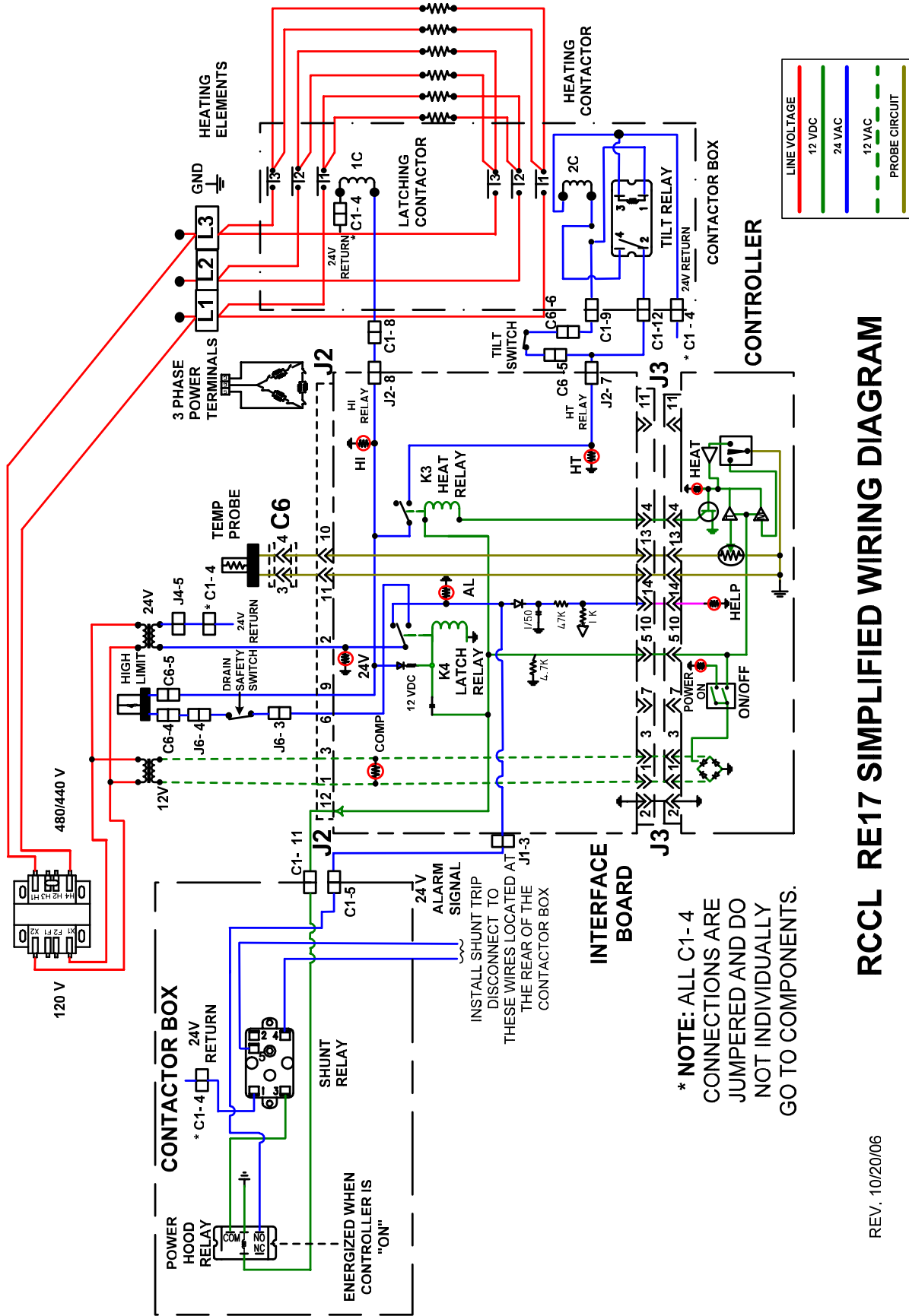

service@frymaster.com

RCCL RE17 SIMPLIFIED WIRING DIAGRAM

REV. 10/20/06

7.13 Wiring Diagram, System

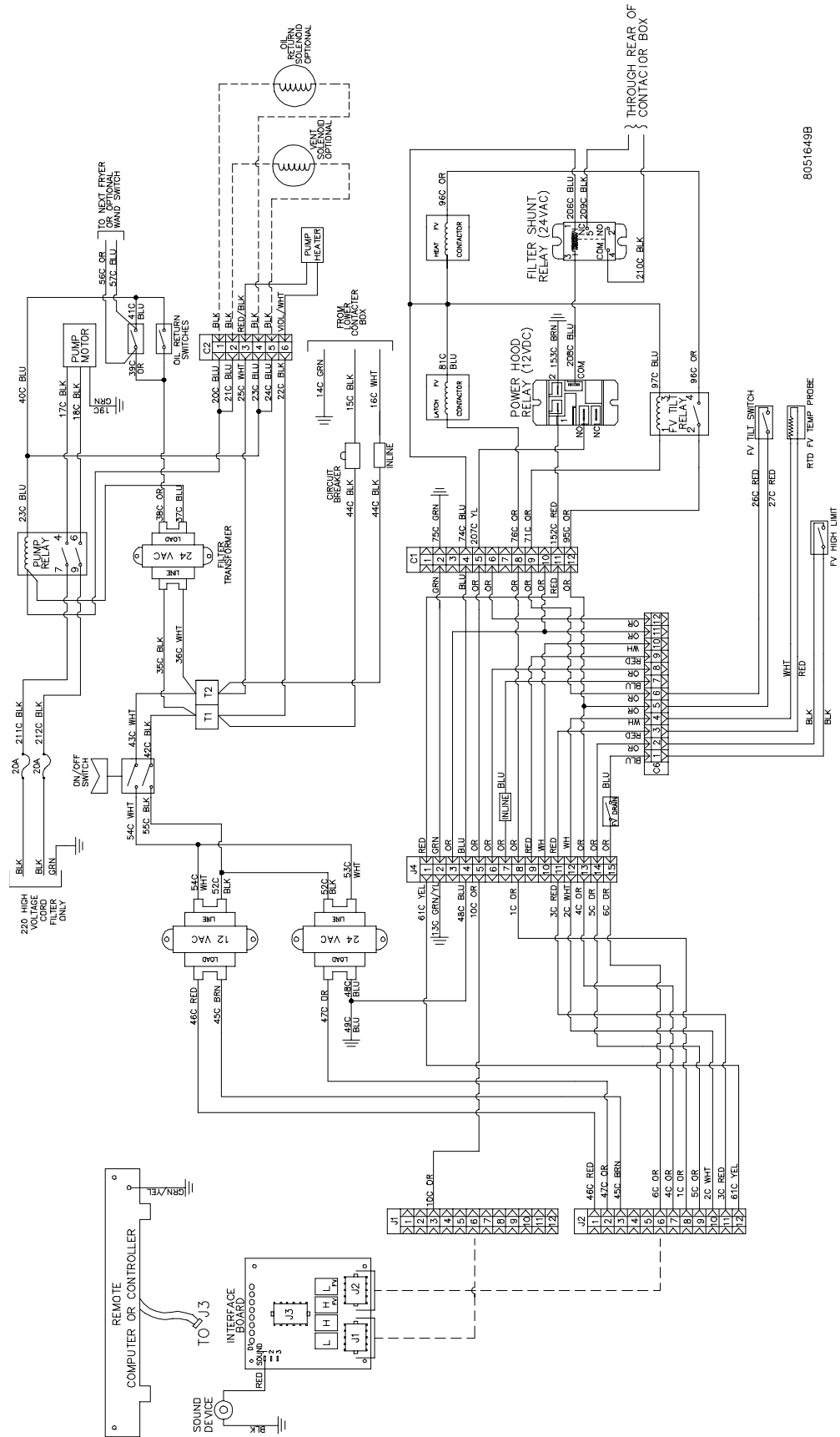

8051649B

7.14 Wiring Diagram, Contactor Box Wiring

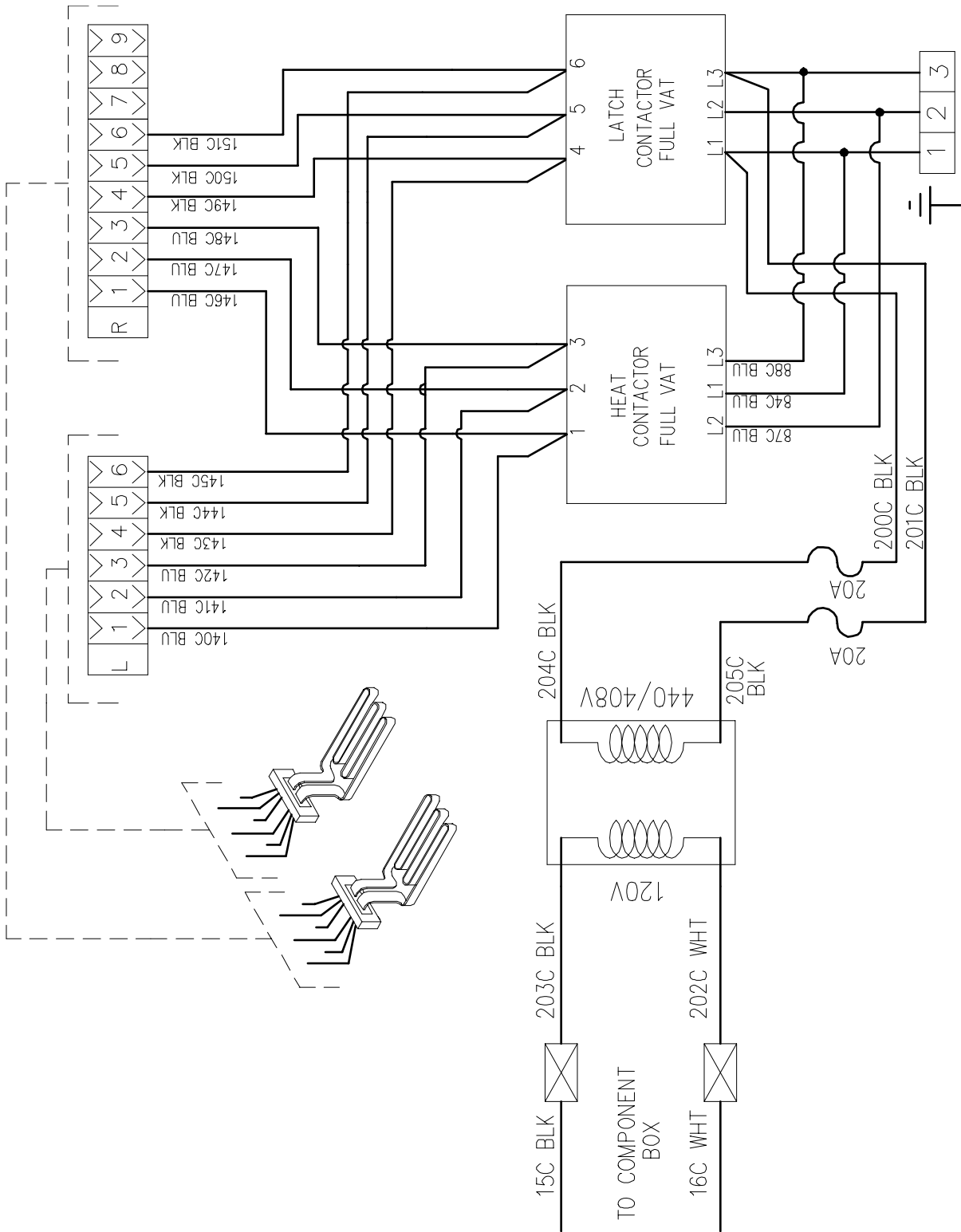

8051641A

7.15 Wiring Diagram, Wiring Harness

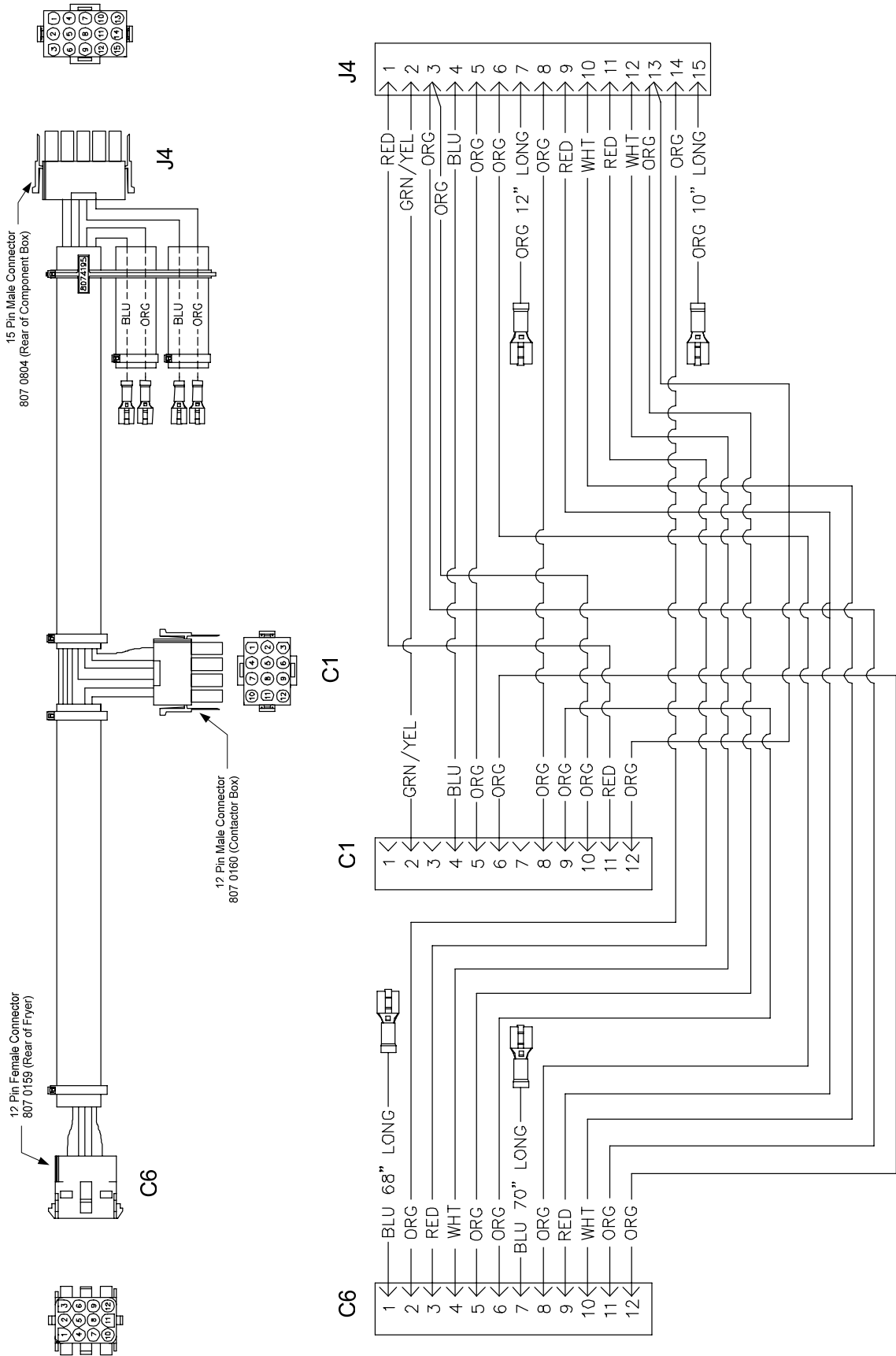

WIRING HARNESS
807-4195

7.16 Wiring Diagram, Remote Cable

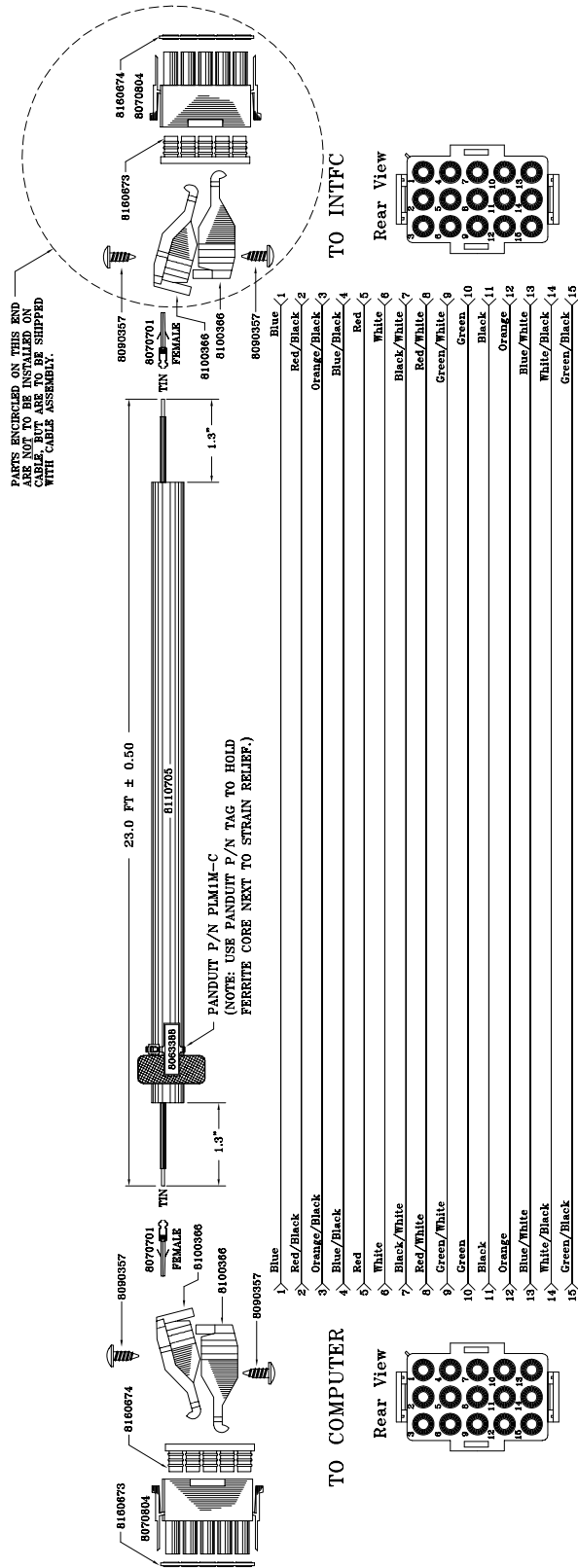

1065142A

RE SERIES MARINE E⁴ ELECTRIC FRYERS

CHAPTER 8: PARTS LIST

8.1 Accessories

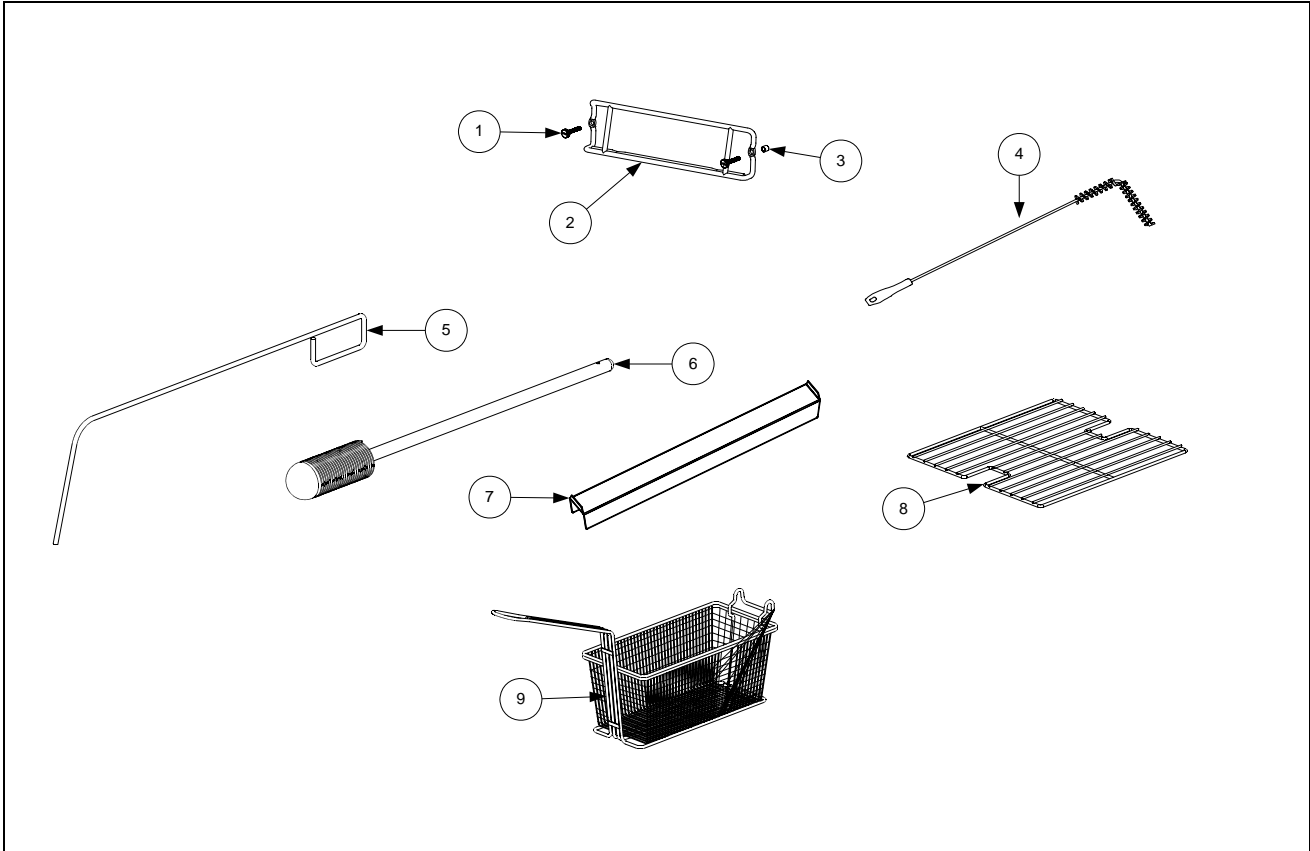

ITEM	PART #	COMPONENT
1	809-0989	Thumbscrew, ¼ -20 X 1-inch
2	810-2793	Hanger, Wireform Basket
3	809-0921	Spacer, Basket Hanger
4	803-0278	L-Shaped Brush
5	803-0197	Cleanout Rod, 27-inch
6	803-0209	Brush, Frypot
7	210-9083	Connecting Strip, Frypot
8	803-0132	Rack, Full-Vat Basket Support
9	803-0271	Basket, Twin
*	803-0352	5/16" Nut Driver
*	803-0293	Gloves, Hot Oil Neoprene
*	803-0002	Powder, Filter (80-8oz Applications)
*	803-0170	Paper, Filter (100-Sheet Pack)

* Not illustrated.

8.2 Cabinetry

8.2.1 Backs, Panels, Doors, Handles, Sides, Tilt Housings & Top Caps

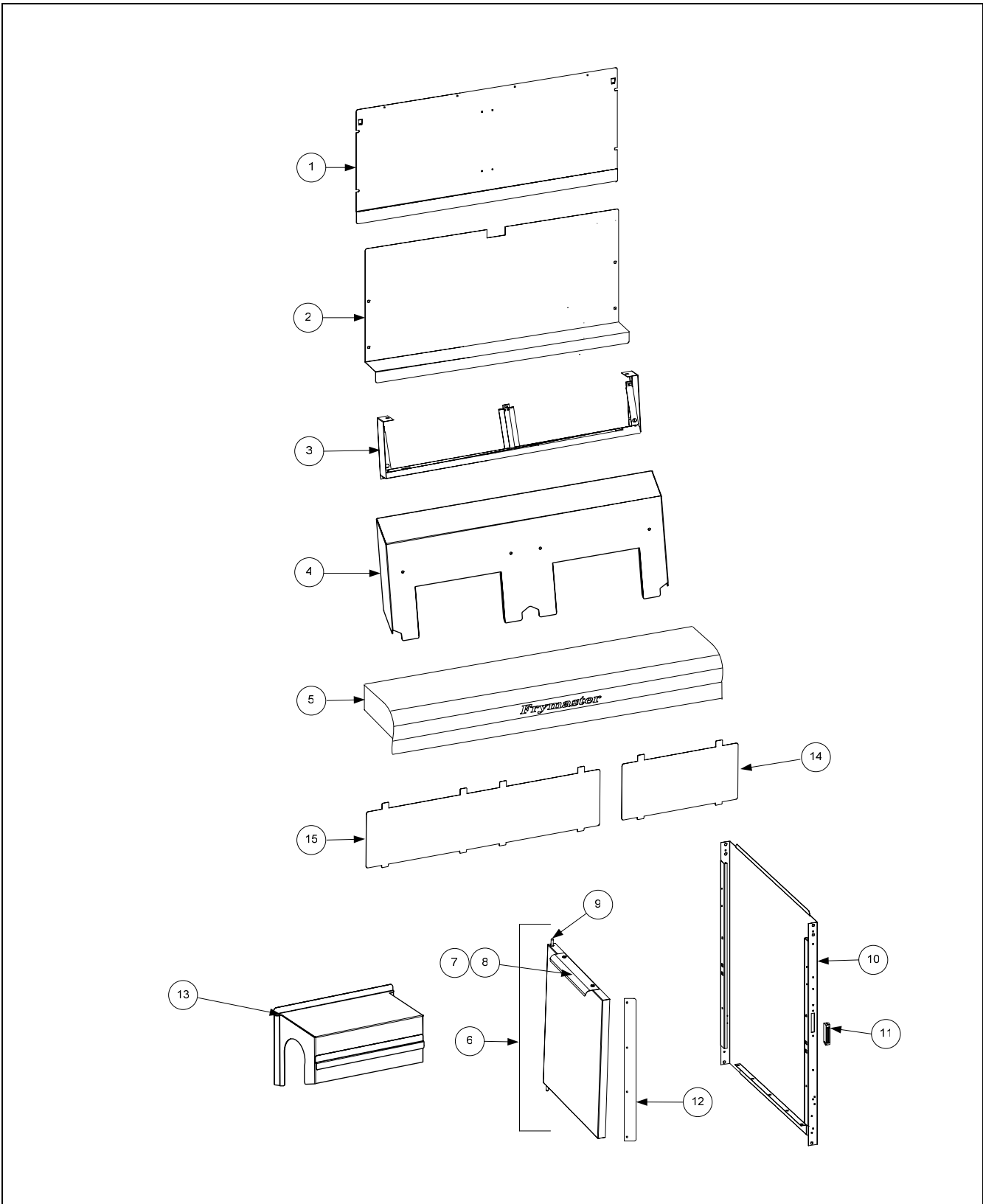

8.2.1 Backs, Panels, Doors, Handles, Sides, Tilt Housings & Top Caps

ITEM	PART #	COMPONENT
1	230-0675	Back Panel, Upper Single FPRE117
	230-0676	Back Panel, Upper 2-Station FPRE217
2	230-0672	Back Panel, Center Single FPRE117
	230-0673	Back Panel, Center 2-Station FPRE217
3	106-5016	Frame, Control Panel, Single FPRE117
	106-5221	Frame, Control Panel, 2-Station FPRE217
4	823-5567	Tilt Housing, Single FPRE117
	823-5484	Tilt Housing, 2-Station FPRE217
5	106-5195	Top Cap, Single FPRE117
	106-5196	Top Cap, 2-Station FPRE217
*	200-9614	Heat Shield, Single FPRE117
*	200-9610	Heat Shield, 2-Station FPRE217
6	106-4979	Door Assembly Single FPRE117 (includes items below plus 210-9214)
*	210-9213	Panel, Door Universal Single FPRE117
*	210-9215	Liner, Door Universal Single FPRE117
*	809-0500	Screw, #10 – ½ Hex TR HD SS
*	826-1343	Spring, Door Pin Hinge Single FPRE117 and FPRE217 (Pkg. of 10)
	106-4769	Door, Left or Right 2-Station FPRE217 (Left shown – move handle to opposite side for Right)
7	809-0500	Screw, #10 X ½-inch Hex Head FPRE217
8	210-9214	Handle, Door
9	106-4067SP	Pin Assembly, Door FPRE117, FPRE217
10	231-1588	Side, Cabinet Left, Single FPRE117
	231-0326	Side, Cabinet Left, 2-Station FPRE217
	232-1588	Side, Cabinet Right, Single FPRE117
	232-0326	Side, Cabinet Right, 2-Station FPRE217
11	810-1105	Magnet, Door
12	210-9086	Door Tab
*	809-0123	Screw, #10 –3/4 Truss Slotted Head
*	826-1376	Nut KEPS 10-32 HX ZP (Pkg. of 10)
*	210-9188	Hinge, Door Single FPRE117
*	809-0970	Retaining Ring – Door Hinge Pin
13	823-5656	Cove, Element Tilt Housing
14	210-5623	Bezel, Insert for Remote Single-Controller
15	210-9085	Bezel, Insert for Remote Double-Controller

* Not illustrated.

8.2.2 Cabinet Bases, Braces, and Associated Parts

8.2.2.1 FPRE117 Single

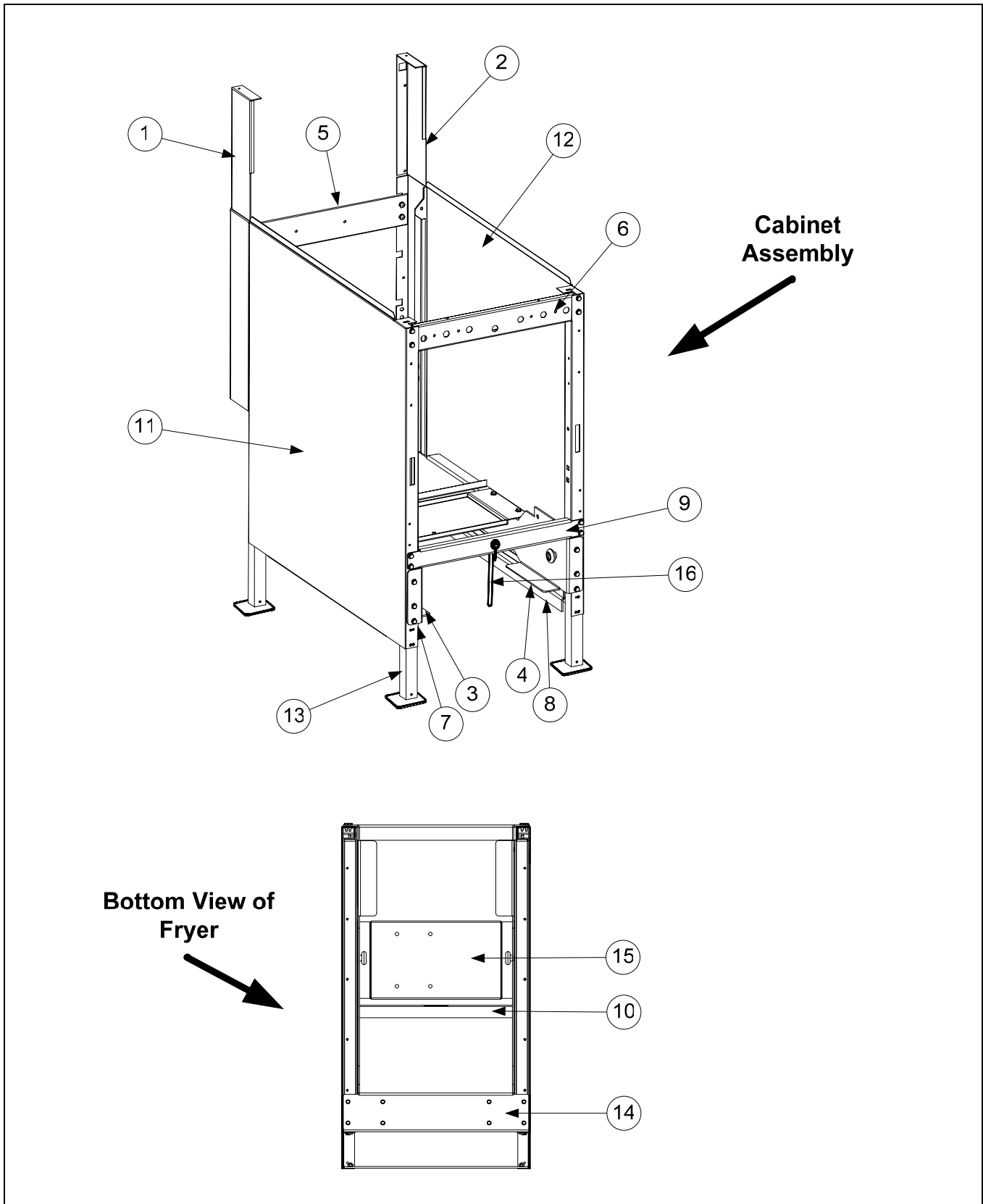

8.2.2.1 FPRE117 Single

ITEM	PART #	COMPONENT
	106-6452	Cabinet Assembly Single Footprint Marine
1	106-4947	Upright Assembly, Enclosure Left
2	106-4946	Upright Assembly, Enclosure Right
3	106-6457	Support Assembly, Left
4	106-6458	Support Assembly, Right
5	230-1502	Brace, Single Rear Horizontal
6	230-1503	Brace, Single Front Horizontal
7	230-1510	Channel, Left Side
8	230-1509	Channel, Right Side
9	230-1505	Support, Cabinet Cross
10	230-1515	Brace, Contactor Box Locking
11	231-1588	Side, Cabinet Left
12	232-1588	Side, Cabinet Right
13	823-5877	Leg
14	823-5589	Channel, Rear Cabinet
15	824-1716	Bridge, Pump/Motor
16	823-5313	Filter Pan Stop
*	809-0782	Washer, 5/16 SS Flat
*	810-0783	Cotter Pin
*	826-1362	Nut, 1/4-20 Hex (Pkg. of 10)
*	809-0191	Washer, 1/4 Lock Spring ZP
*	809-0500	Screw, #10 - 1/2 Hex Head SS
*	809-0417	Nut, Flange 1/4 - 20
*	809-0508	Bolt, 14 - 20 x 1 1/4 AT HX HD SS

* Not illustrated.

8.2.2.2 FPRE217 Double Station Fryer

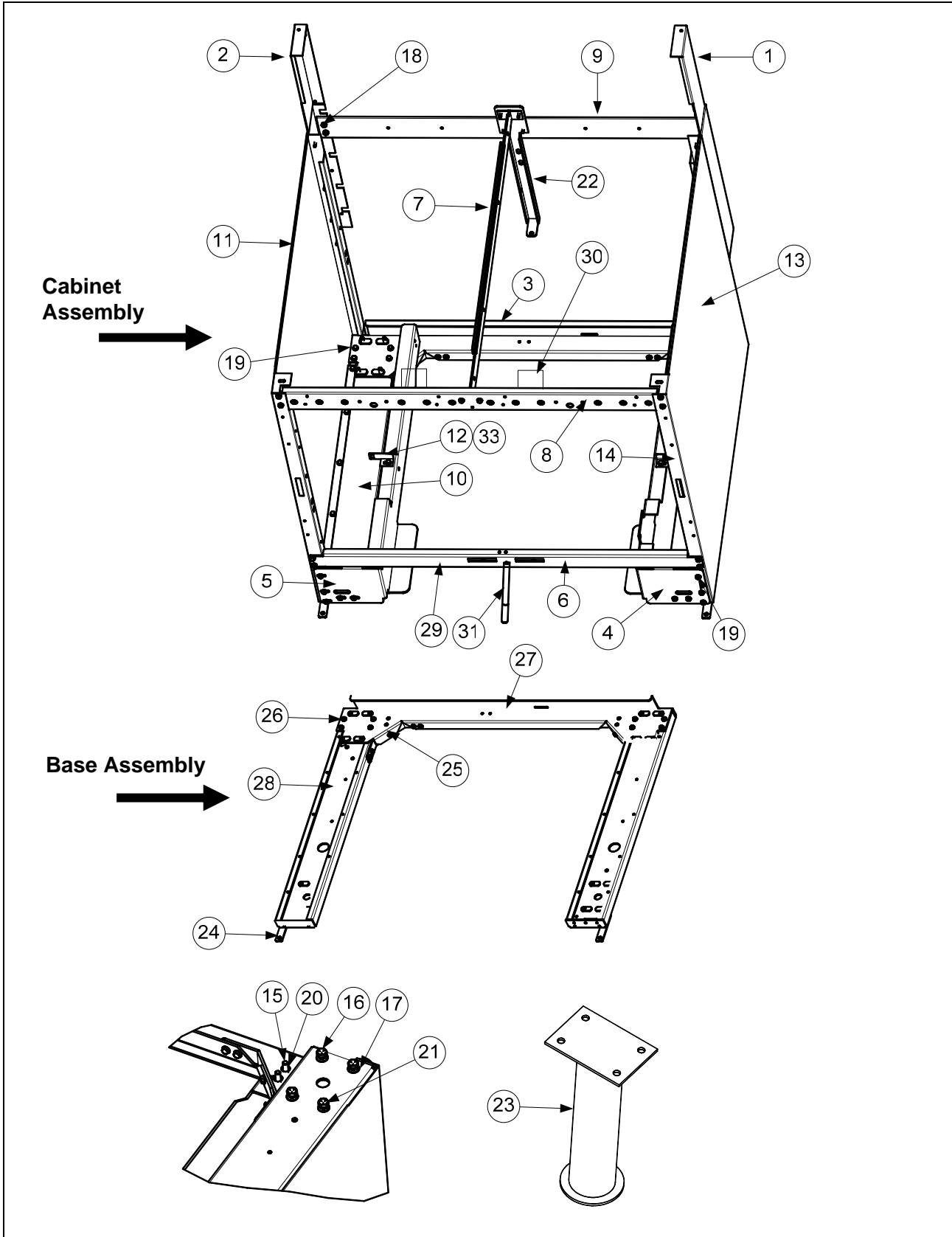

8.2.2.2 FPRE217 Double Station Fryer

ITEM	PART #	COMPONENT
	106-4919	Cabinet Assembly, FPRE Electric Double S/S
1	106-4946	Upright Assembly, Right
2	106-4947	Upright Assembly, Left
3	106-4767	Base Assembly, FPRE Double Electric
4	210-8978	Support, Right Filter Pan
5	210-8979	Support, Left Filter Pan
6	210-8984	Support, Cross Cabinet
7	210-8986	Divider, Cabinet
8	210-8987	Brace, Front Horizontal Two-Station Fryer
9	210-8989	Brace, Rear Horizontal Two-Station Fryer
10	210-9116	Shield, Channel
11	231-0326	Side, Left Cabinet
12	231-0811	Bracket, RE LH Contactor Box Mounting Station 1
13	232-0326	Side, Right Cabinet
14	232-0811	Bracket, RE RH Contactor Box Mounting Station 2
15	826-1389	Screw, Hex Head 1/4"-20x 3/4" (Pkg. of 10)
16	809-0190	Washer, Flat 1/4" SS
17	809-0191	Washer, 1/4" Lock Spring
18	826-1376	Nut, 10-32 Keps Hex (Pkg. of 10)
19	826-1374	Screw, #10x 1/2-inch Hex Washer Head (Pkg. of 25)
20	809-0417	Nut, 1/4" -20 Hex Flange
21	809-0429	Bolt, 1/4"-20 x 2-inch Hex Head
22	824-1488	Bracket, Rear Support
23	823-5241	Leg, Marine Shipboard (Mounts with Items 20 and 21)
24	210-9033	Hinge, Door
25	210-8993	Brace, Rear Channel Corner
26	809-0500	Screw, #10 X 1/2-inch Hex Washer Head SS
27	823-5105	Channel, Base Rear Two-Station Fryer
28	823-5106	Channel, Base Side
29	810-2346	Magnet, Door
30	210-9023	Bracket, Frypot
31	823-5313	Filter Pan Stop
*	809-0782	Washer, 5/16 SS Flat
*	810-0783	Cotter Pin

* Not illustrated.

8.3 Drain System Components

8.3.1 FPRE217 Euro-Look Drain Tube Sections and Associated Parts

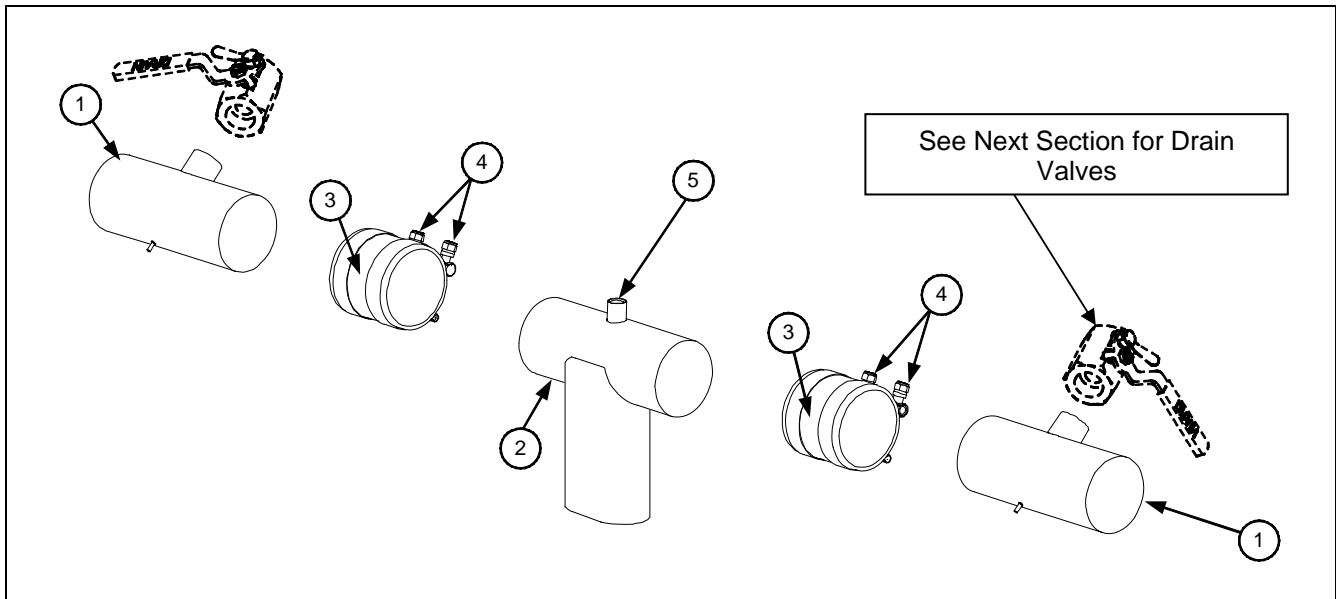

ITEM	EURO-LOOK PART #	COMPONENT
1		Drain Tube, Left/Right End Short
	823-5048	Full-Vat
2	823-5049	Drain Outlet
3	816-0625	Sleeve
4	809-0969	Clamp
5	810-2492	Fitting, Quick-Connect Straight (receives Teflon vent tube)
*	811-1071	Tube, Teflon Vent (sold by the foot)

Not illustrated.

8.3.2 Drain Valve Assembly and Component Parts

8.3.2.1 FPRE117 Single Drain Valve Assembly

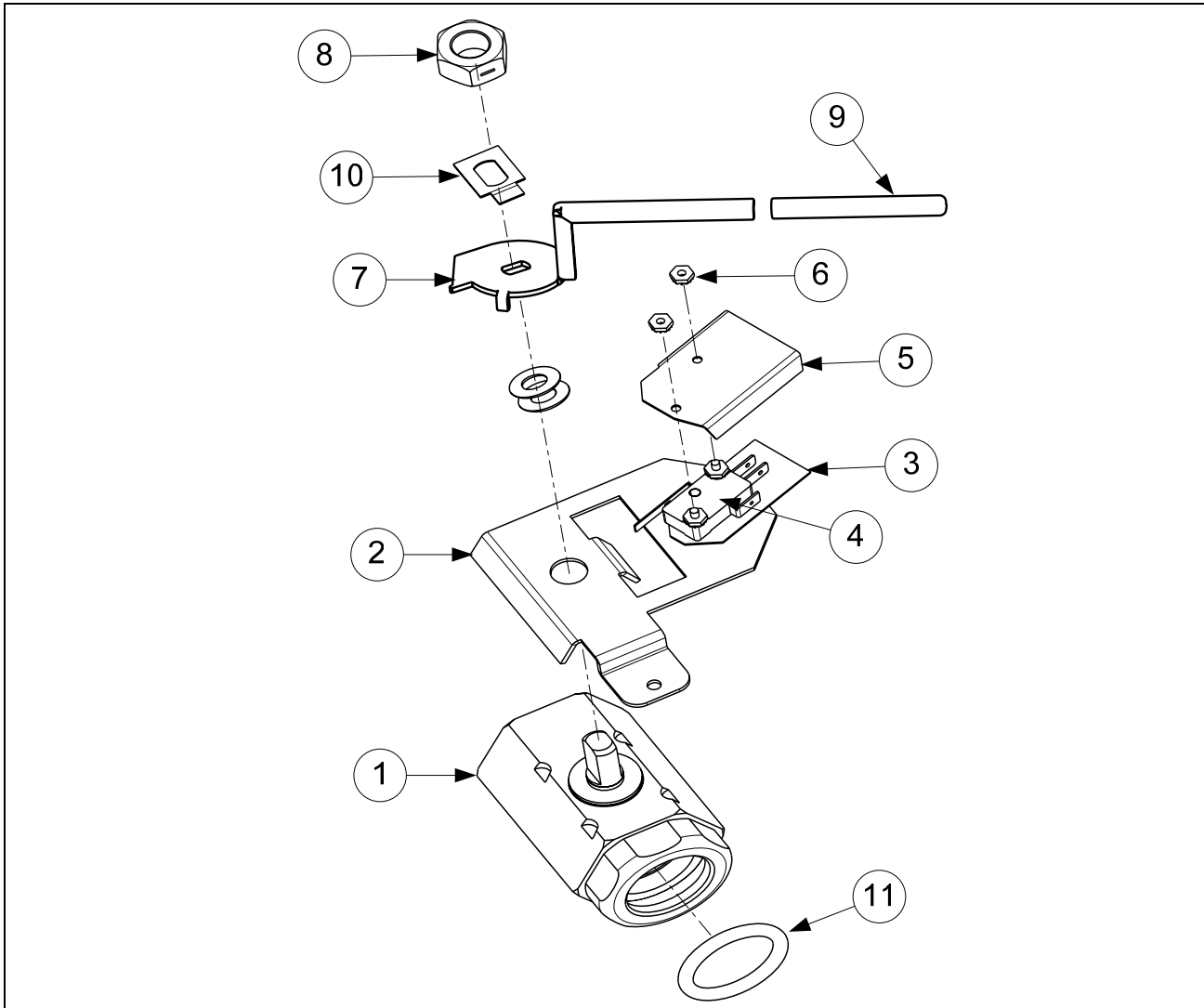

ITEM	PART #	COMPONENT
	106-4962	Valve Assembly, Full Vat Drain
1	810-2946	Valve, 1¼-inch Full-Vat Drain Single SS
2	106-5391	Bracket Assembly, Full-Vat Drain Safety Switch
3	816-0220	Insulation, Drain Safety Switch
4	807-2103	Microswitch, CE Straight Lever
5	210-9178	Cover, Dual Vat Drain Safety Switch
6	826-1366	Nut, 4-40 Keps Hex (Pkg. of 25)
7	824-1602	Handle, Full-Vat Drain Valve
8	210-9203	Nut, ½-13 2-Way Hex Lock SS
9	816-0639	Cap, Red Handle
10	210-9177	Retainer, Nut Drain Valve FV
11	816-0135	O-Ring, Round Drain
*	823-5592	Tube, Drain Single Station Fryer Only with Filter

* Not illustrated.

8.3.2.2 FPRE217 Drain Valve Assembly and Component Parts

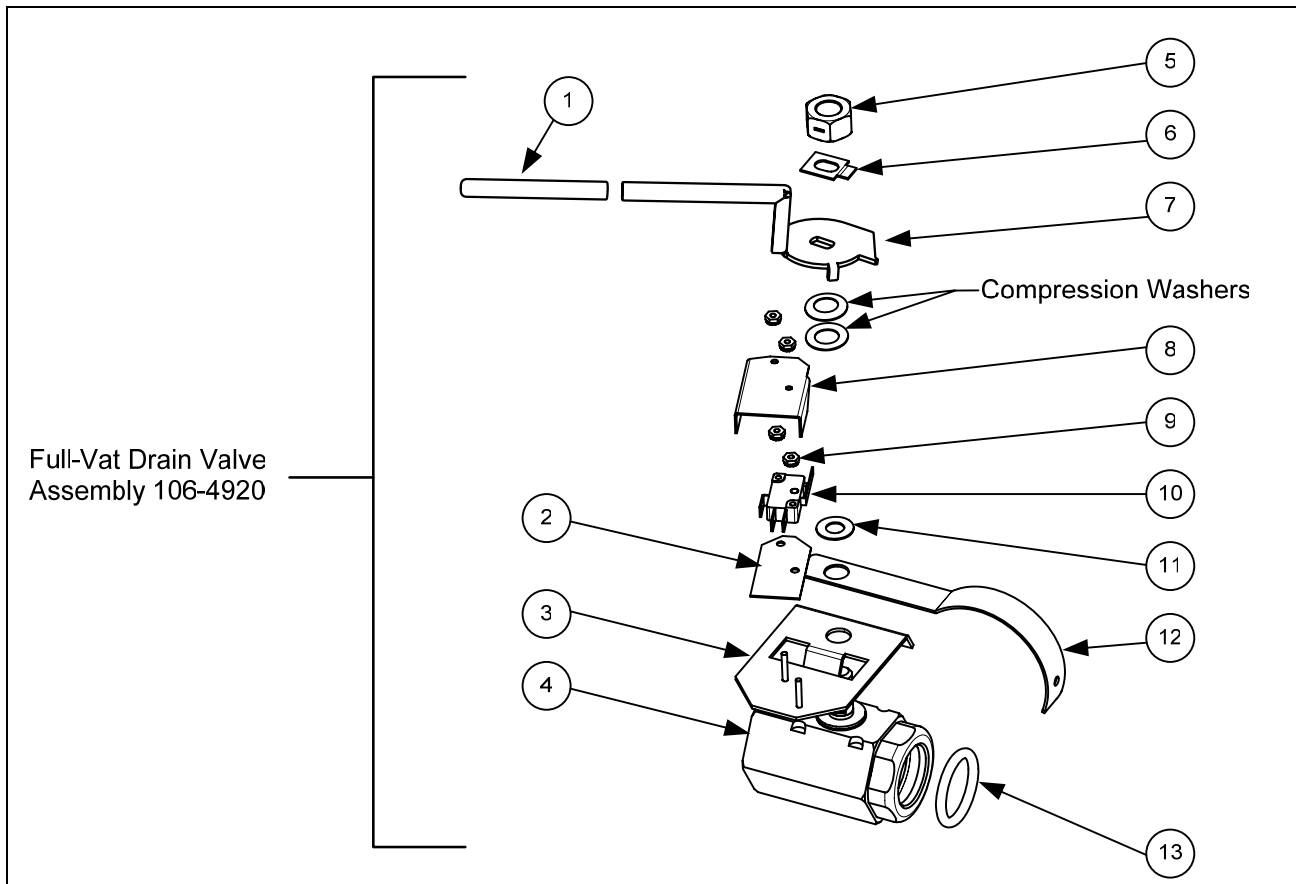

ITEM	PART #	COMPONENT
	106-4920	Valve Assembly, Full Vat Drain
1	816-0639	Cap, Red Handle
2	816-0220	Insulation, Drain Safety Switch
3	806-8137	Bracket Assembly, Full-Vat Drain Safety Switch
4	810-2946	Valve, 1.25-inch Full-Vat Drain
5	809-0540	Nut, ½-13 2-Way Hex Lock
6	210-9177	Retainer, Full-Vat Drain Valve Nut
7	824-1602	Handle, Full-Vat Drain Valve
8	210-9178	Cover, Dual Vat Drain Safety Switch
9	826-1366	Nut, 4-40 Keps Hex (Pkg. of 25)
10	807-2103	Microswitch, CE Straight Lever
11	810-1165	Washer, Teflon Drain Valve
12	210-8966	Support, 3" Drain
13	816-0135	O-Ring, Round Drain
*	WIR0572	Wire Bundle, Drain Safety Switch

* Not illustrated.

8.4 Electronics and Wiring Components

8.4.1 Component Boxes

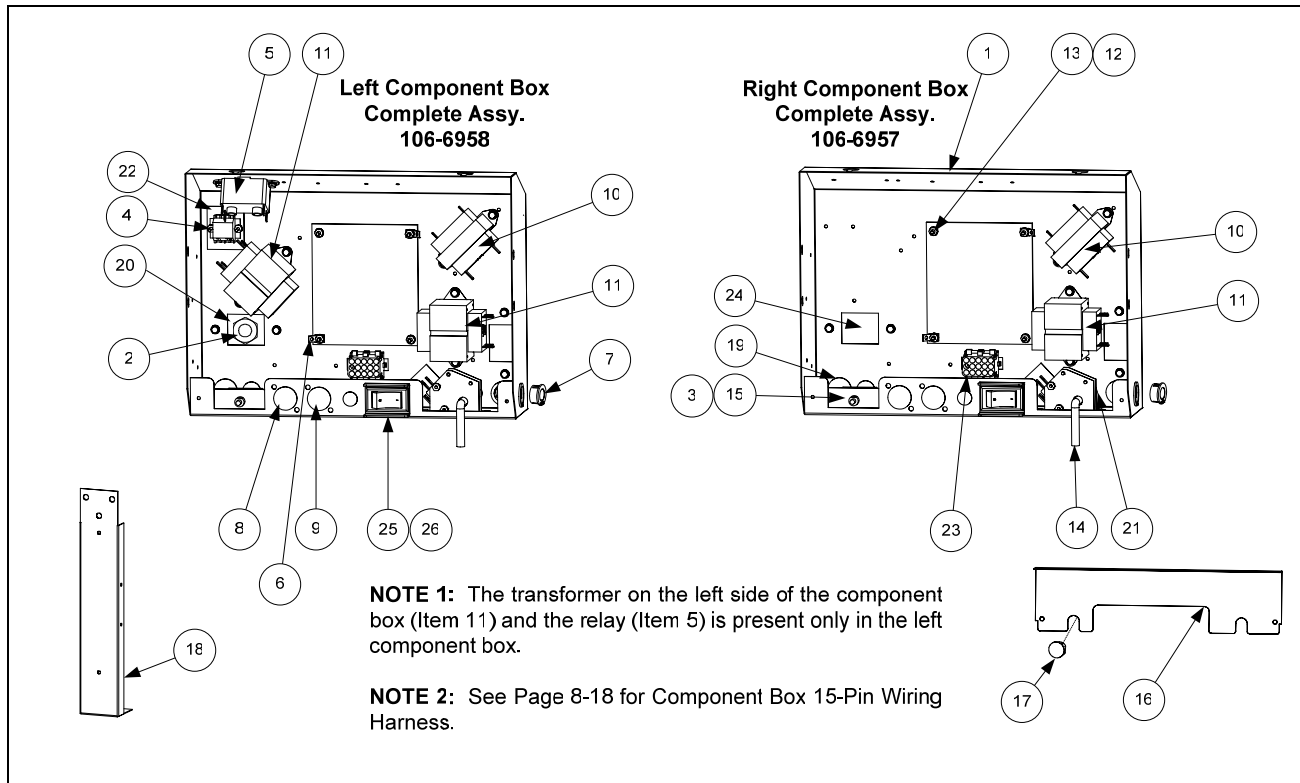

ITEM	PART #	COMPONENT
1	106-5846	Box Assembly, Component
2	809-0582	Washer, Locking
3	230-1057	Bracket, Circuit Breaker
4	806-9495SP	Terminal Block and Wire Assembly
5	807-0012	Relay, Filter 18 Amp 1/3 HP 24V Coil
6	826-1337	Terminal, 1/4-inch Push-on (Pkg. of 5)
7	810-0045	Bushing, .875 Dia. Hole 11/16"
8	807-1947	Plug, .875
9	810-2446	Plug, .50 Heyco Double "D"
10	807-0855	Transformer, 100-120V/12V 20VA
11	807-2180	Transformer, 208-240V/24V 50VA Filter (<i>used with 220V Motors</i>)
	807-0800	Transformer, 100-120V/24V 50VA Filter (<i>used with 120V Motors</i>)
12	809-0349	Spacer, 4mm X 6mm Aluminum
13	106-6811	Interface Board (<i>on SMT boards the relays are not replaceable</i>)
	807-3932	Relay, Heat/Latch 12VDC SPDT 12 Amp Sealed (<i>on SMT boards the relays are not replaceable</i>)
14	106-5848	Handle Assembly, Oil Flush FV
15	807-0069	Circuit Breaker, 10 Amp
16	230-0812	Guard, Finger
17	810-2445	Plug, Button .625 Heyco Double "D"
18	210-8995	Brace, Component Box
19	807-1083	Bushing, Heyco

continued on the following page....

8.4.1 Component Boxes cont.

ITEM	PART#	COMPONENT
20	807-3868	Strain Relief
21	807-0121	Bushing, Heyco SB-625-500
22	816-0217	Paper, Insulating Terminal Block CE
23	106-5750	Harness, Full Vat Assembly
24	220-0083	Plate, Strain Relief
25	807-4036	Switch
	807-3575	Plug, Carling Switch Hole <i>(used in place of a switch on some models)</i>
26	230-0834	Guard, RE Box Switch

8.4.2 Contactor Boxes

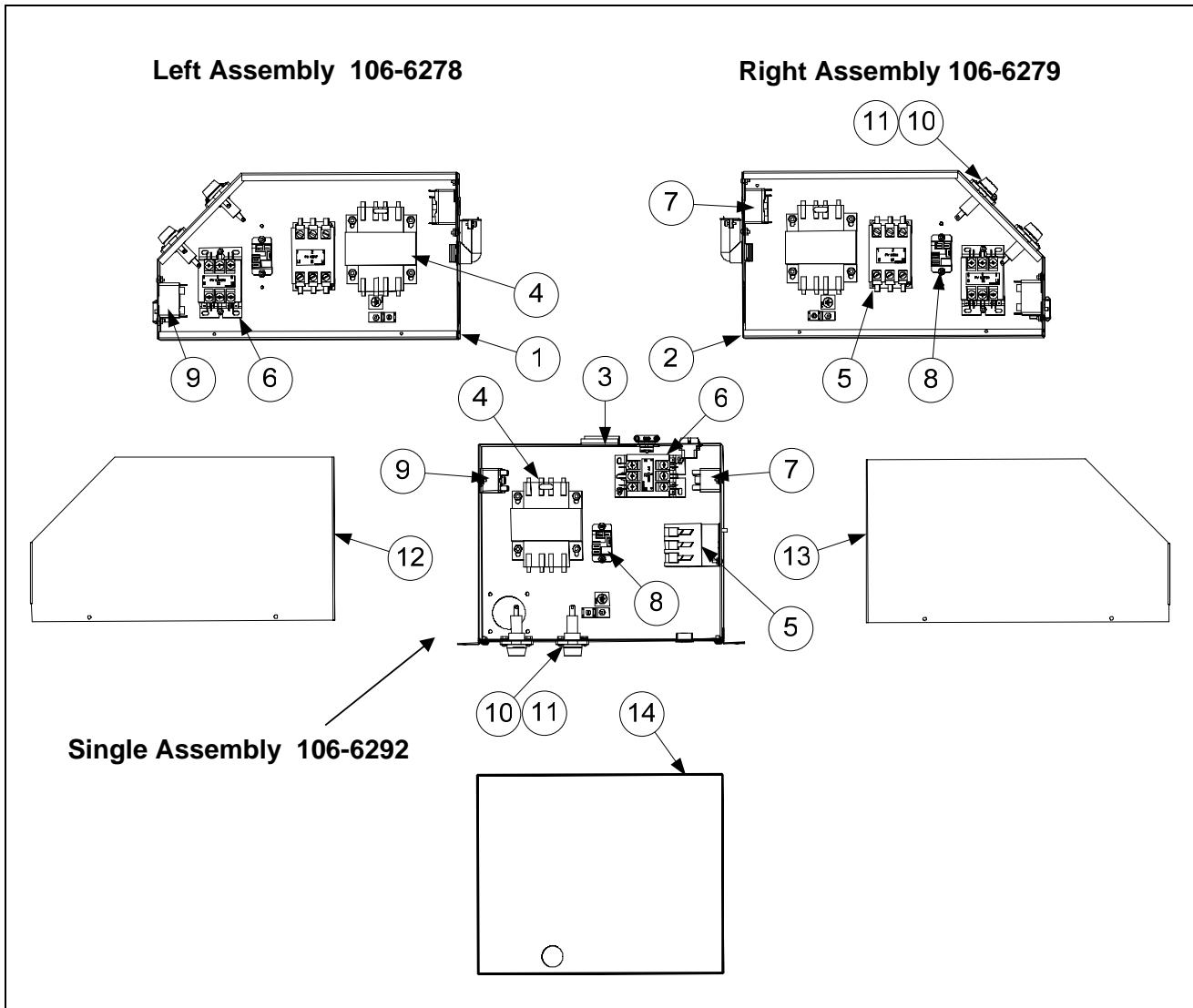

NOTE 1: Left and right contactor box assemblies are mirror images of one another. With the exception of the box itself, all components of a left-hand assembly, are the same as those in the corresponding right-hand assembly and vice versa.

NOTE 2: See Page 8-17 for Contactor Box Wiring Assembly

continued on the following page...

8.4.2 Contactor Boxes cont.

ITEM	PART #	COMPONENT
1	106-6124	Box Assembly, FPRE Left Contactor
2	106-6125	Box Assembly, FPRE Right Contactor
3	106-6288	Box Assembly, Single Foot Print Contactor
4	807-0064	Transformer, 480V/120V 150VA
5	807-2284	Contactor, 24V 50 Amp Mechanical
6	810-1202	Contactor, 24V 40 Amp Mechanical
7	807-2434	Relay, Shunt 24V Coil 18 Amp
8	807-1683	Relay, Power 12 VDC
9	807-0012	Relay, Tilt 18 Amp 1/3 HP 24V Coil
10	807-0922	Holder, Bus Fuse
11	807-2278	Fuse, 20 Amp
12	231-1135	Cover, RE Left Hand
13	232-1135	Cover, RE Right Hand
14	230-1377	Cover, RE Single Foot Print
*	231-0811	Bracket, Left Hand Contactor Box Mounting RE
*	232-0811	Bracket, Right Hand Contactor Box Mounting RE
*	WIR0751	Wire Assembly, Filter Shunt Relay
*	WIR0726	Wire Assembly, Hood Relay
*	WIR0712	Wire Assembly, Latch and Hood Relay

* Not illustrated.

8.4.3 Terminal Blocks

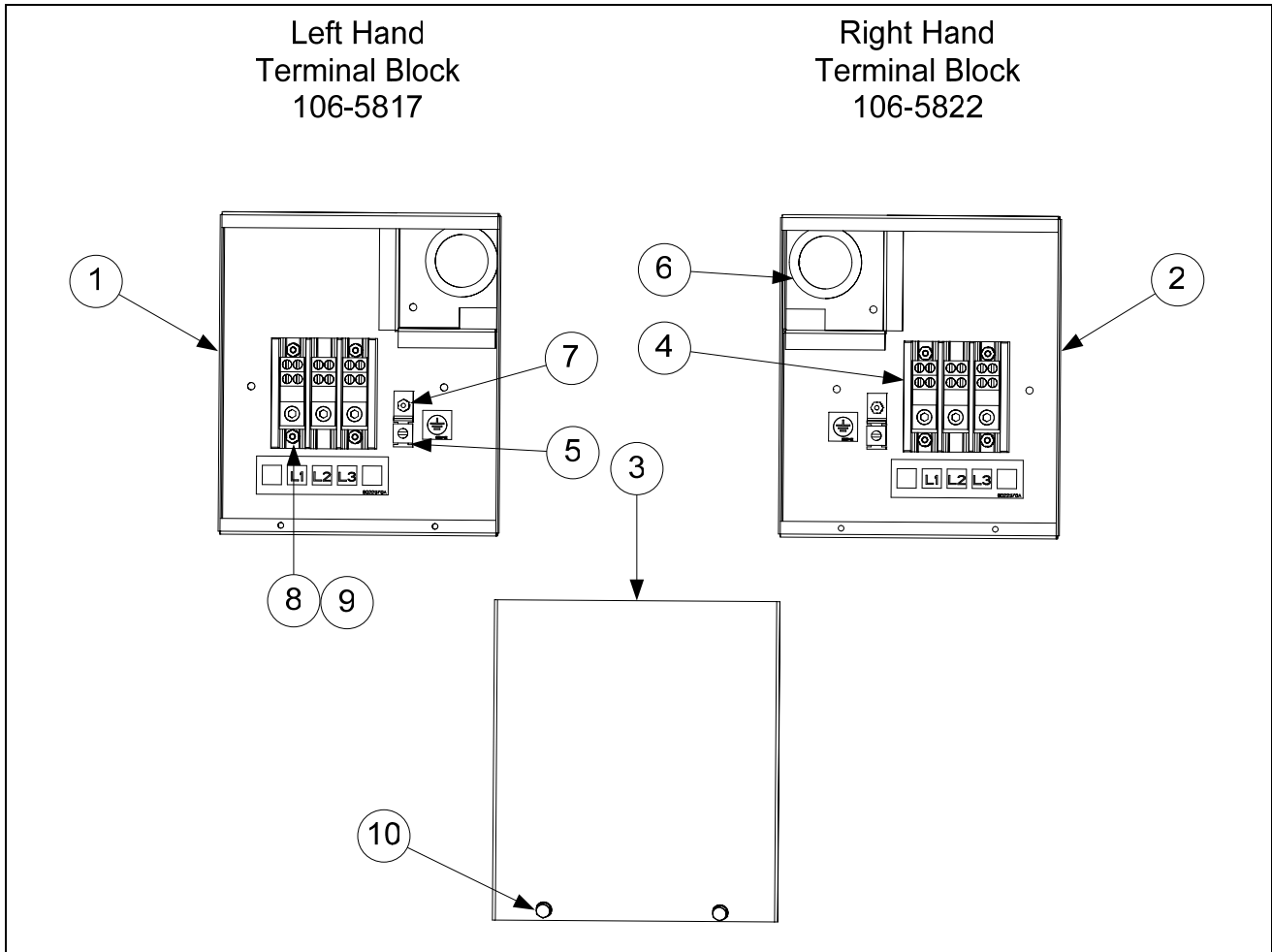

ITEM	PART #	COMPONENT
1	823-5631	Box, LH Rear Terminal Block
2	823-5632	Box, RH Rear Terminal Block
3	220-0801	Cover, Rear Terminal Block Box
4	807-3970	Block, 3 Pole 600V 175A
5	807-0070	Terminal, Ground Lug
6	807-0128	Bushing, Insulating Heyco
7	809-0247	Nut, #8-32 Hex
8	809-0250	Nut, #6-32 Hex
9	826-1363	Screw, #8-32 x 1/2" Hex Head (Pkg. of 25)
10	826-1374	Screw, #10 - 1/2" Hex Head (Pkg. of 25)

8.4.4 Heating Element Assembly and Associated Parts

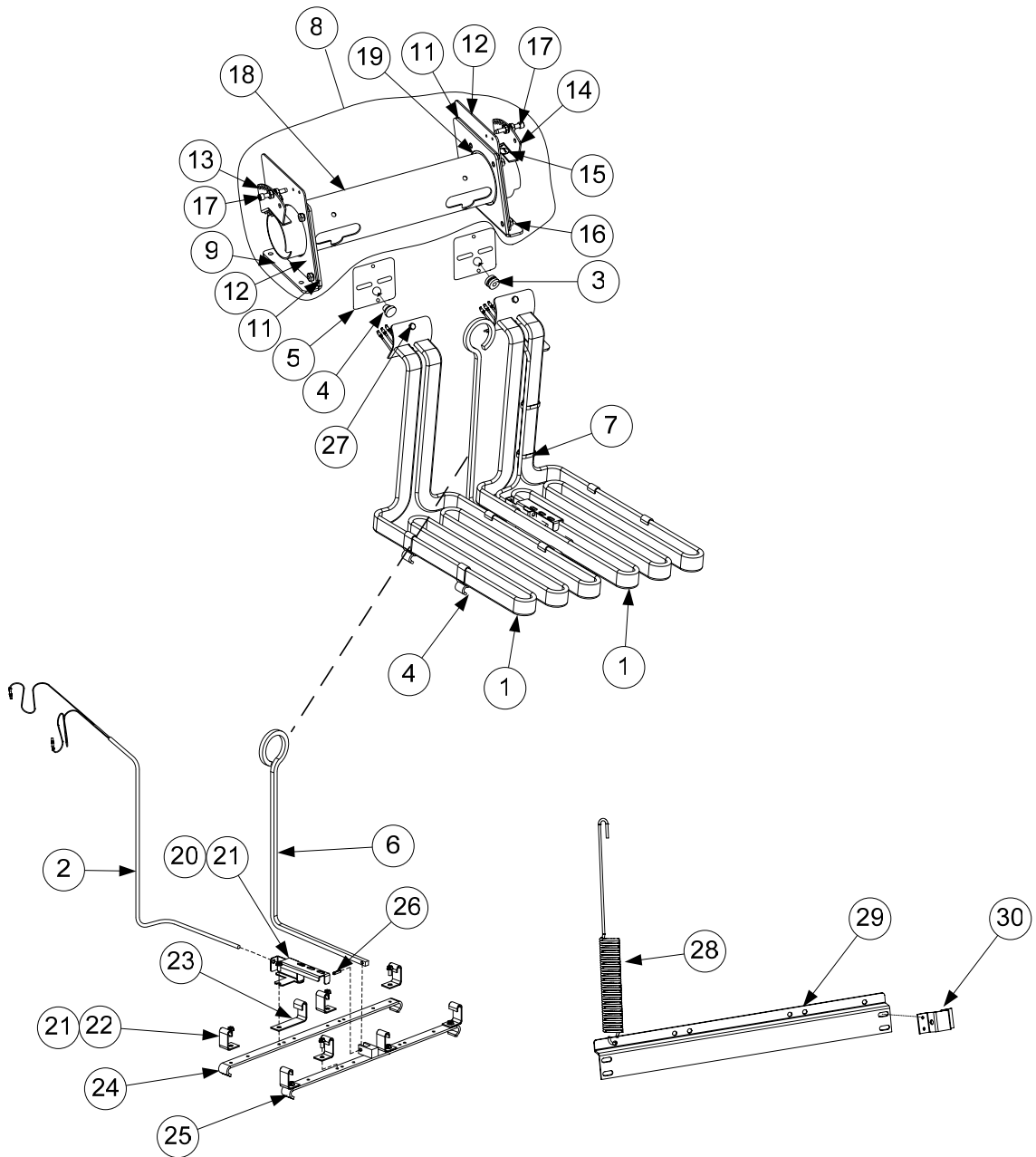

NOTES:

The only difference between element assemblies for different voltage and kW ratings is the element itself (Item 1).

Items 28, 29 and 30 are shown as associated parts. They are not part of either assembly.

This manual references only the new “RE” elements. For previous model fryers and related parts prior to May 2006 see manual 819-6118.

8.4.4 Heating Element Assembly and Associated Parts cont.

ITEM	PART #	COMPONENT
	106-5554	Element Assembly FV 440V 17kW w/ Lift Handle Single FPRE117
	106-5558	Element Assembly FV 480V 17kW w/ Lift Handle FPRE217
1	826-2202	Element, 440V 8.5kW
	826-2203	Element, 480V 8.5kW
2	826-2212	Probe, Temperature Kit RE (includes tie wraps and grommet)
3	816-0681	Grommet, Probe
4	816-0480	Plug, .375-inch Dome
5	816-0688	Gasket, Element
6	810-1233	Handle, Element Lift SS
7	809-0567	Tie-Wrap, Metal
8	106-5590	Tube Assembly RE Element, Full-Vat
9	106-5588	Bracket Assembly, LH Element Tube Support
10	106-5589	Bracket Assembly, RH Element Tube Support
11	230-0554	Plate, Element Tube Support Inner
12	230-0553	Plate, Element Tube Support Outer
13	106-6569	Bracket Assembly, LH Upper Spring
14	106-6570	Bracket Assembly, RH Upper Spring
15	826-1330	Screw, 10-32 X $\frac{3}{8}$ -inch Slotted Truss Head SS (Pkg. of 25)
16	809-0766	Nut, 10-32 Hex HD SS
17	809-1000	Screw, 10-32 x $\frac{1}{4}$ -inch Hex
18	106-6037	Tube, FV Element Mounting
19	810-2993	Bushing, Tube End Teflon
20	230-0850	Bracket, Temperature Probe
21	809-0518	Screw, 8-32 X $\frac{3}{8}$ -inch Slotted Hex Head SS
22	210-9180	Clamp, Element (Short)
23	230-0781	Clamp, Element (Long)
24	230-0849	Bracket RE, Full-Vat Element Rear
25	823-5657	Bracket RE, Full-Vat Element Front
26	826-1364	Pin, .125 X .5-inch Split (Pkg. of 25)
27	809-1003	Screw, 10-32 X $\frac{3}{8}$ -inch Hex Head SS (<i>uses 809-0766 Nut 10-32 SS</i>)
28	810-3030	Spring, Element Lift Left
	810-3031	Spring, Element Lift Right
29	220-1190	Bracket, Lower Spring Single Foot Print
	220-0464	Bracket, Lower Spring
30	220-0733	Bracket, Lower Spring Mating
*	106-6587	Magnetic Position Sensor
*	810-3007	Magnet
*	230-0794	Bracket, Magnetic Position Sensor Wire

* Not illustrated.

8.4.5 Remote Digital Controller

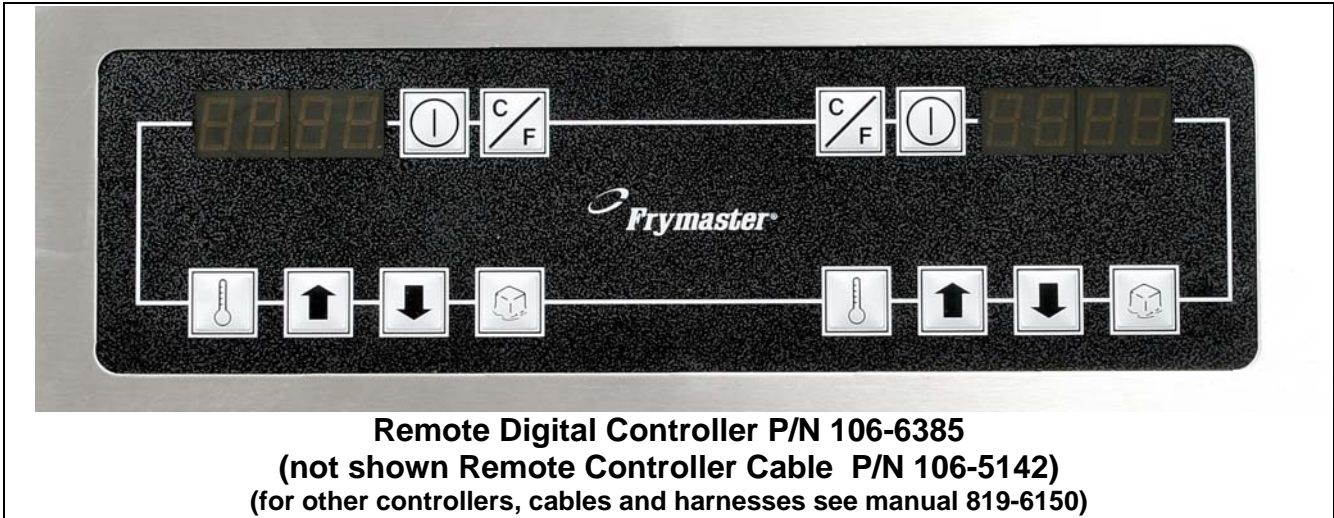

8.4.6 Wiring Assemblies and Harnesses

8.4.6.1 Contactor Box Wiring Assembly – 12-Pin Full-Vat C-1

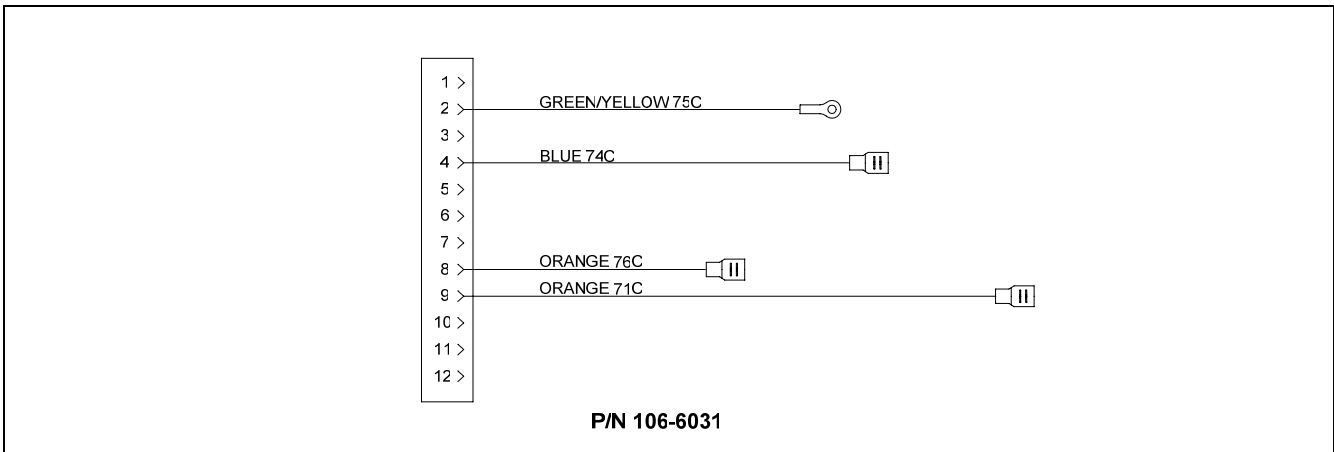

8.4.6.2 Contactor Box Wiring Assemblies – 6-Pin (Left Element)

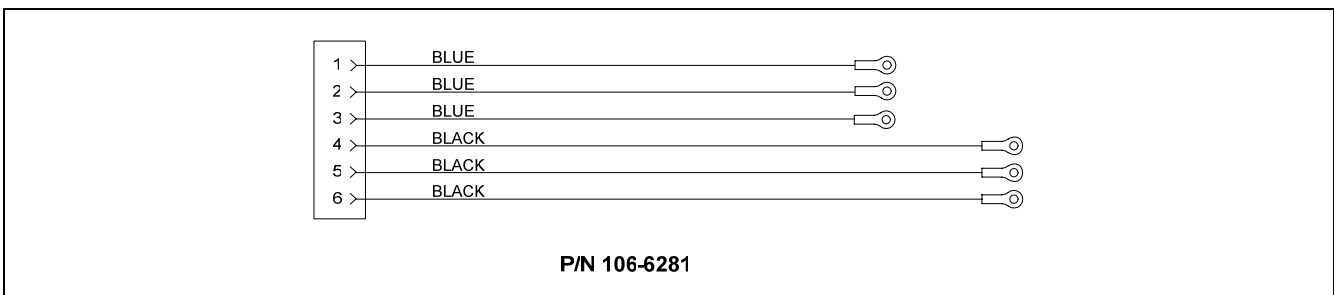

8.4.6.3 Contactor Box Wiring Assemblies – 9-Pin (Right Element)

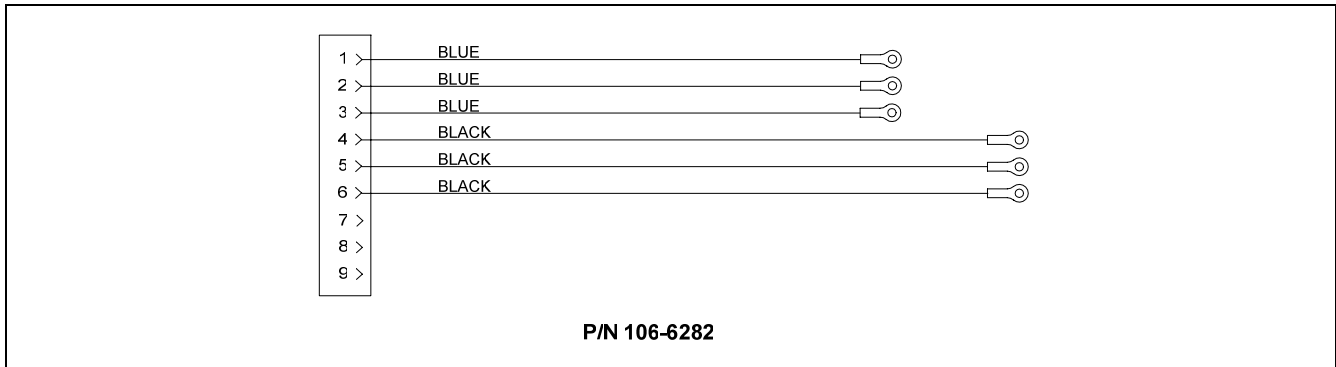

8.4.6.4 Main Wiring Harness

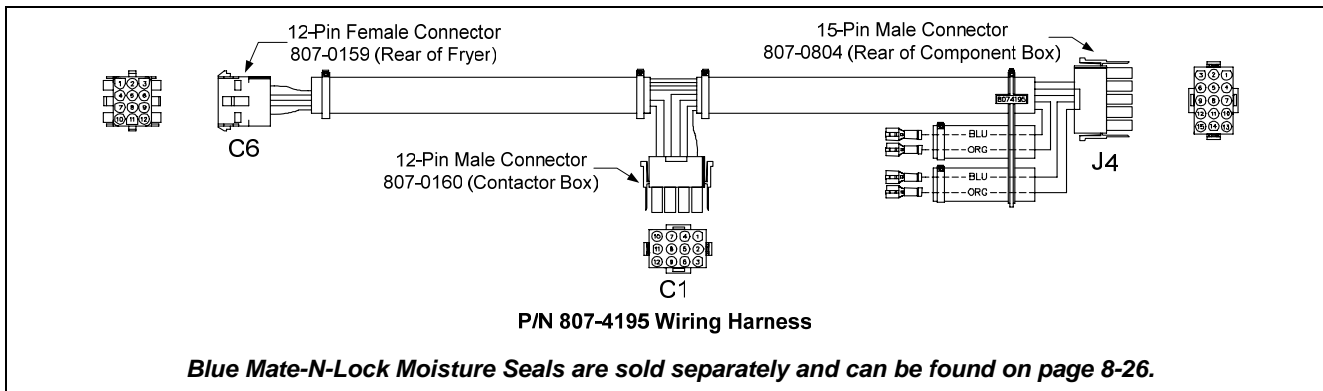

8.4.6.5 Component Box and Filter Pump Wiring Harnesses

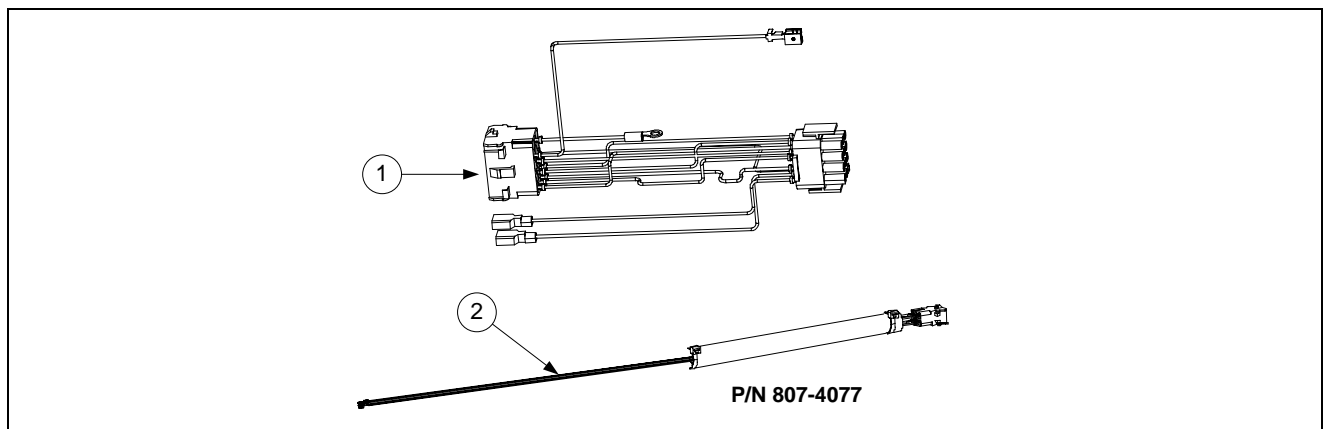

ITEM	PART #	COMPONENT
1	106-5750	Full Vat Control Harness J4 to J2 (<i>WIR0765 required with this harness</i>)
2	106-5935	Filter Pump C2 to Component Box Wiring Harness

8.5 Filtration System Components

8.5.1 FPRE117 Single Filtration Components

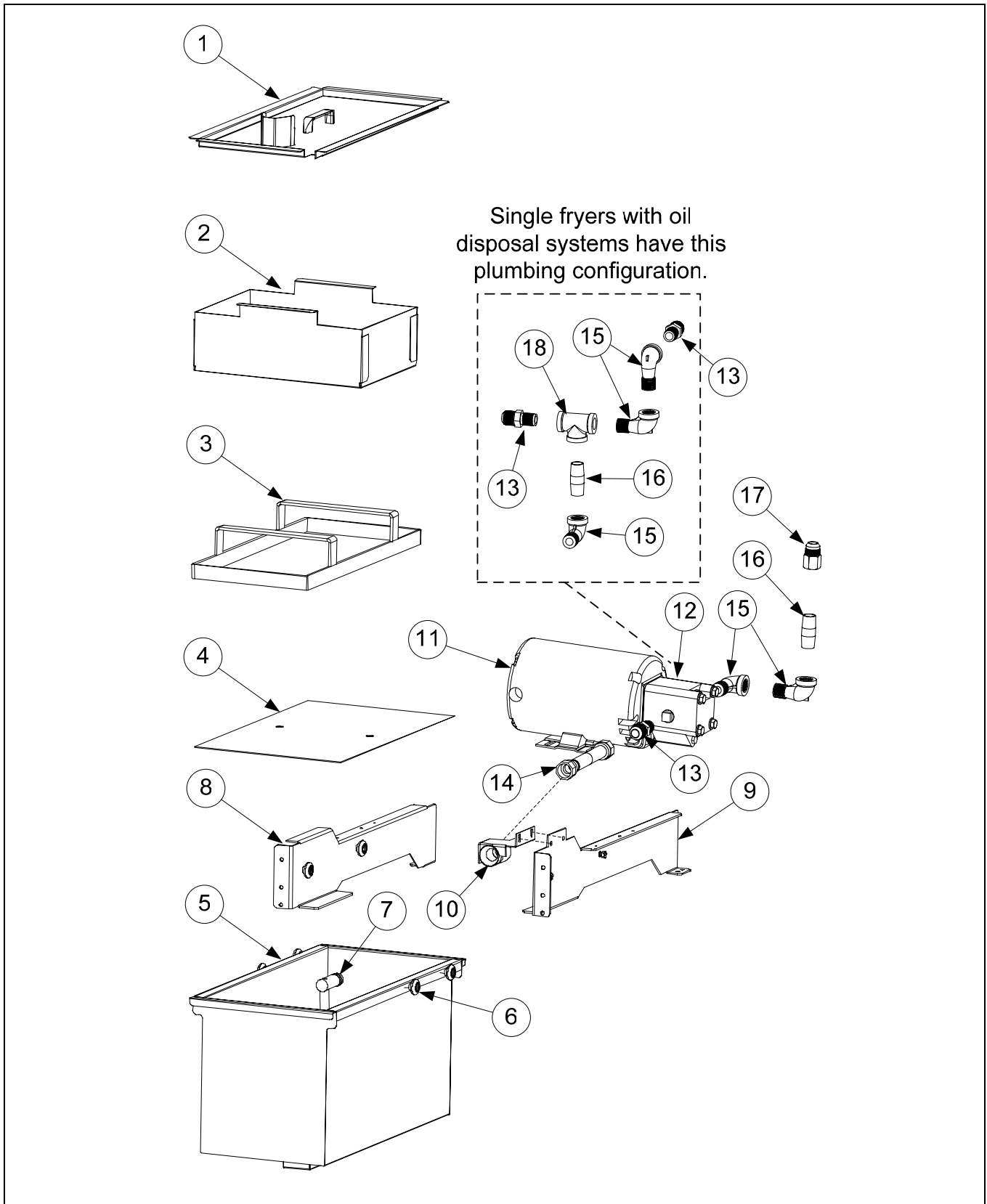

8.5.1 FPRE117 Single Filtration Components cont.

ITEM	PART #	COMPONENT
	106-6519	Assembly, Filter Pan Single FPRE117 includes pan and lid
1	106-6516	Lid, Assembly Single FPRE117
2	824-1707	Crumb Tray
3	823-5774	Hold Down Ring - Paper
4	220-1316	Sana Grid Filter Screen
5	823-5879	Pan, Filter
6	810-2198	Roller, Filter Pan Rail (used with Item 8 and 9)
*	826-1979	Filter Pan Roller Kit (four each of Items 6 and 826-1372)
*	826-1372	Nut, ¼-20 Hex (Pkg. of 10)
*	810-2012	Rail Set, Filter Pan Roller (includes one left and one right)
7	826-1392	O-Ring (Pkg. of 5; used with Item 5)
8	106-5981	Support, Assy. Left Filter Pan
9	106-5982	Support, Assy. Right Filter Pan
10	823-5862	Fitting, Female Suction Tube
11	826-1270	Motor and Gasket Kit, 220-240V 50/60Hz
	826-1712	Motor and Gasket Kit, 110-120V 50/60Hz
12	826-1264	Pump and Gasket Kit
*	807-11973	Viking Pump Seal Kit
13	810-1668	Adapter, ⅝-inch to ½-inch NPT Male
14	810-1680	Flexline, 6.5-inch Oil Return
15	813-0616	Elbow, ST ½-inch x ½-inch NPT 90° SS
16	813-0912	Nipple, ½-inch 2.0-inch SS
17	810-1669	Adapter, ⅝-inch to ½-inch NPT Female
18	810-2343	Tee, ½-inch SS
*	803-0170	Filter Paper
*	106-2852SP	Heater Strip Assembly, 208-250V 25W 18"
*	806-5933SP	Heater Strip Assembly, 100-120V 25W 18"

* Not illustrated.

8.5.2 FPRE217 Filtration Components

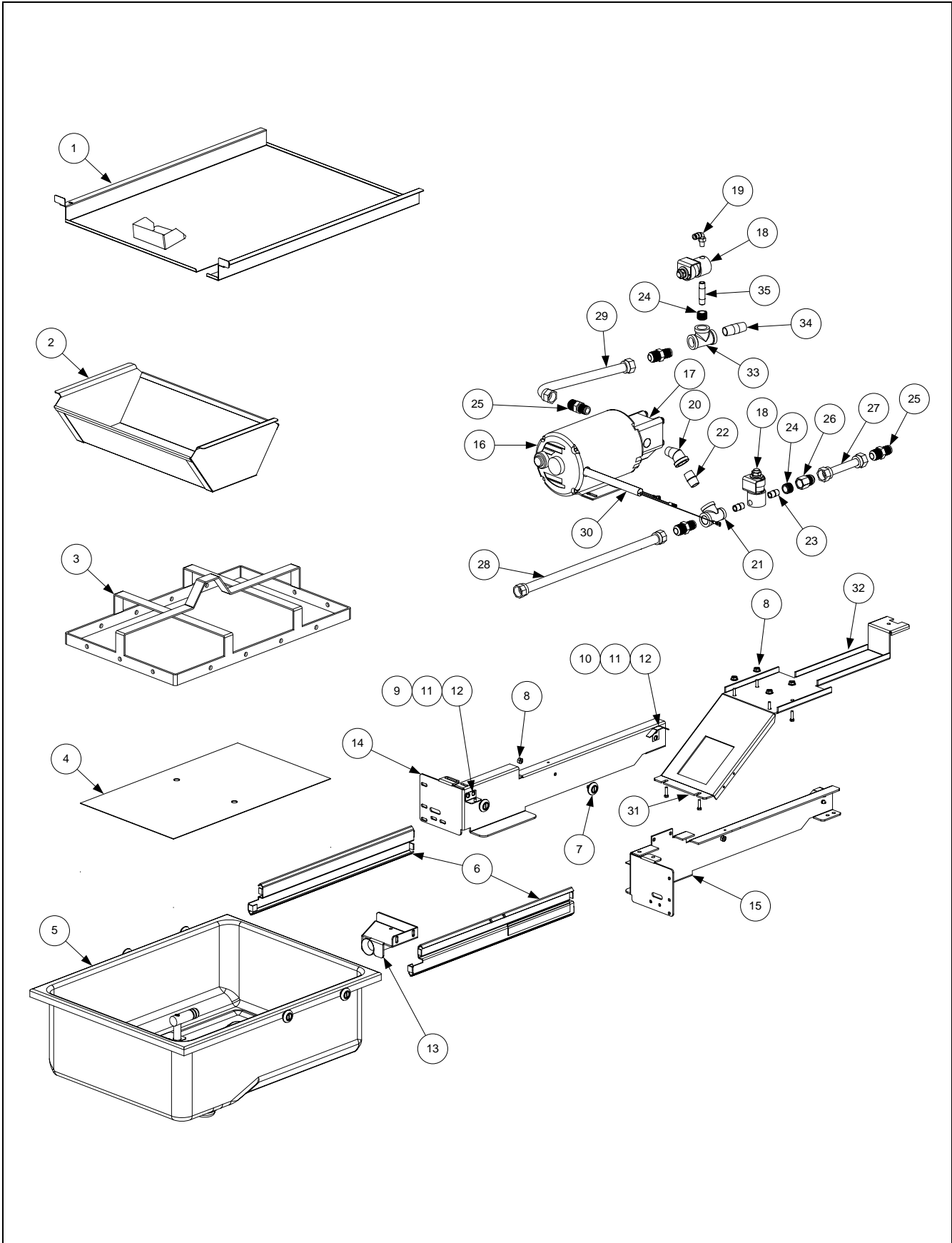

8.5.2 FPRE217 Filtration Components cont.

ITEM	PART #	COMPONENT
*	826-1979	Filter Pan Roller Kit (four each of Items 7 and 8)
*	826-1980	Service Filter Pan (Item 5 minus Item 2)
*	826-1981	Service Filter Pan Assembly (Service Filter Pan above plus Items 3 and 4)
*	826-1392	O-Ring (Pkg. of 5; used with Item 5)
*	813-0568	Plug, 1/8-inch Socket Head Pipe (component of Item 5; two required)
*	811-1071	Tubing, 1/4-inch OD Teflon Vent (sold by the foot)
*	106-2852SP	Heater Strip Assembly, 208-250V 25W 18"
*	806-5933SP	Heater Strip Assembly, 100-120V 25W 18"
1	823-5130	Lid, Filter Pan
2	810-3161	Crumb Tray (component of Item 5)
3	810-2091	Hold Down Ring
4	200-2124	Sana Grid Filter Screen
5	106-4925	Pan, One-Piece Filter (includes Item 2,)
6	810-2012	Rail Set, Filter Pan Roller (includes one left and one right)
7	810-2198	Roller, Filter Pan and Rail (includes screws)
8	826-1372	Nut, 1/4-20 Hex (Pkg. of 10) (use 809-0191 for Washer, Lock 1/4-inch)
9	823-4675	Bracket, Lid Support
10		Guide, Filter Pan Lid
	210-9000	Left
	210-9005	Right
11	809-0503	Screw, 8-32 X 1/2-inch Slotted Truss Head
12	809-0247	Nut, 8-32 Hex Keps
13	823-5133	Suction Tube
14	210-8979	Rail, Left Filter
15	210-8978	Rail, Right Filter
16	826-1270	Motor and Gasket Kit 220-240V 50/60Hz
	826-1712	Motor and Gasket Kit 110-120V 50/60Hz
17	826-1264	Pump and Gasket Kit 4 GPM 2-piece
	816-0093	Gasket, Pump/Motor
*	807-11973	Viking Pump Seal Kit
18	807-2484	Valve, 1/4-inch Solenoid
19	810-2493	Fitting, 1/4 -inch x 90° Quick Connect
20	813-0342	Elbow, 1/2-inch 45° Street
21	813-0530	Tee, 1/2-inch X 1/4-inch X 1/2-inch Reducing
22	813-0087	Nipple, 1/2-inch Close
23	813-0838	Nipple, 1/4-inch Close
24	813-0304	Bushing, 1/2-inch to 1/4-inch Flush
25	810-1668	Adapter, 5/8-inch to 1/2-inch NPT Male
26	810-1669	Adapter, 5/8-inch to 1/2-inch NPT Female
27	810-1680	Flexline, 6.5-inch Oil Return
28	810-1057	Flexline, 13.0-inch Oil Return
29	810-1043	Flexline, 11.5-inch Oil Return
30	807-3828	Cable, FootPrint Pro Pump Motor
31	826-1375	Screw, 10-32 X 3/4-inch Hex Trim Head (Pkg. of 5)
32	210-9016	Bridge, Filter Motor
33	813-0003	Tee, 1/2-Inch
34	813-0298	Nipple, 1/2-inch 2.0-inch
35	813-0537	Nipple, 1/4-inch 2.0-inch
*	810-1043	Flexline, 9.5-inch Oil Return
*	803-0170	Filter Paper

* Not illustrated

8.6 Frypot Assembly and Thermostat

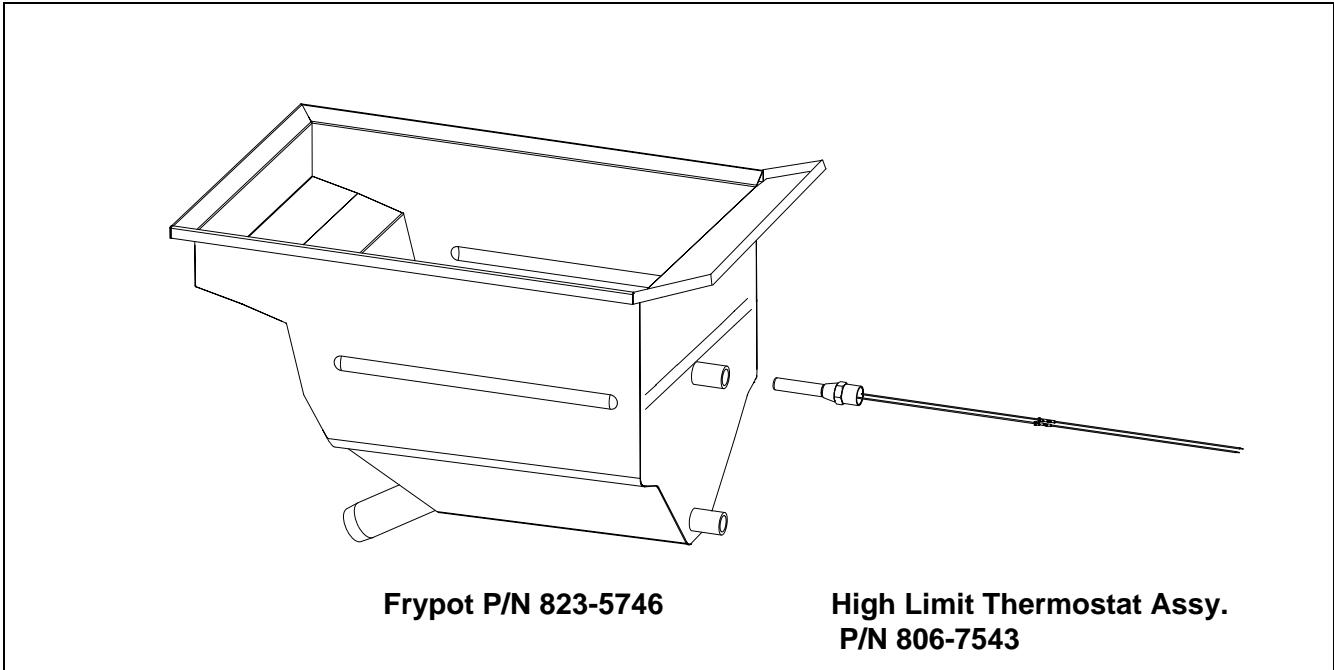

8.7 Oil Return System Components

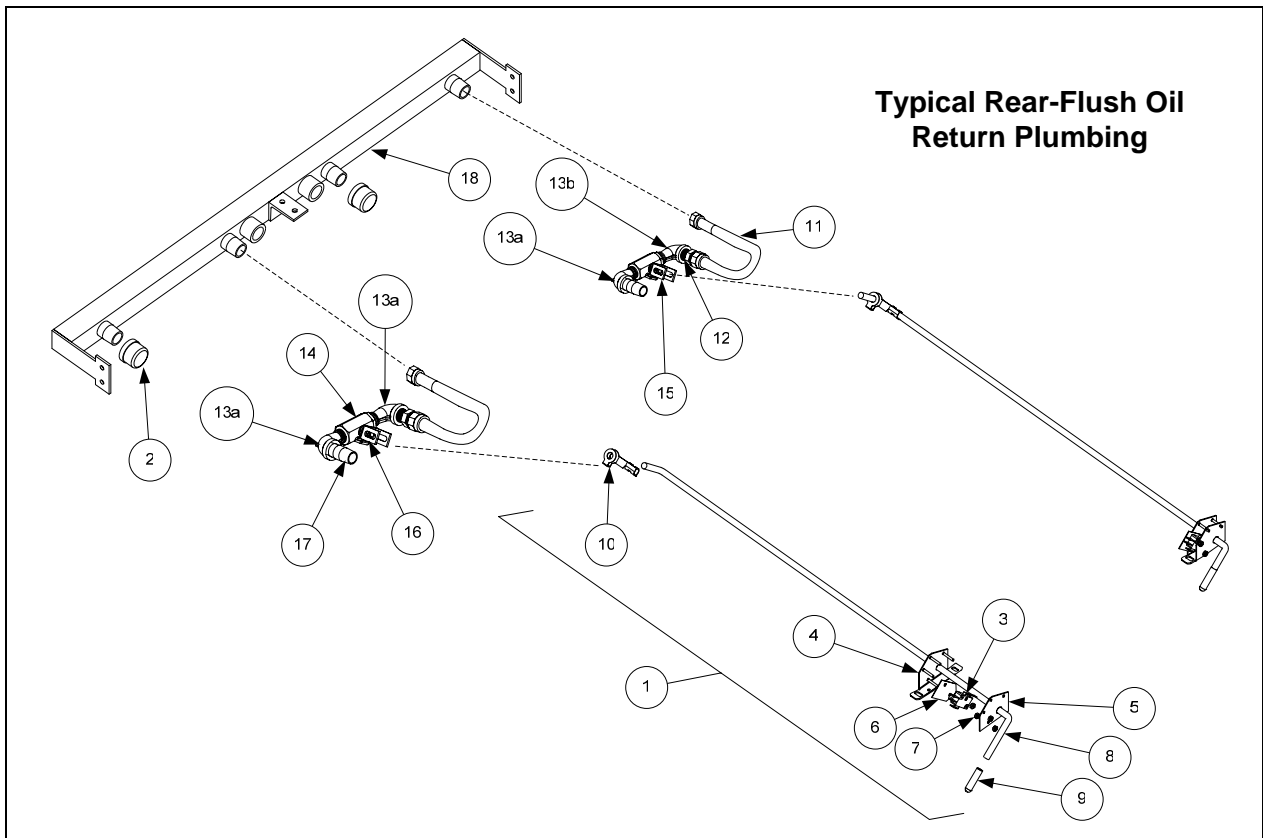

8.7 Oil Return System Components cont.

ITEM	PART #	COMPONENT
1	106-5848	Handle Assembly, Rear Flush
2	813-0907	Cap, 15/16-inch Valve Safety
3	807-2103	Microswitch, Straight Lever
4	106-5847	Bracket Assembly
5	210-8998	Bracket, Handle Retainer
6	816-0220	Insulation, Oil Return Microswitch
7	826-1366	Nut, 4-40 Keps Hex (Pkg. of 25)
8	810-3105	Rod, Handle
9	816-0643	Grip, Oil Return Valve Handle
10	809-0601	Clip, Clevis
11	810-2532	Flexline, 7.0-inch
*	810-1057	Flexline, 13.0-inch
12	810-1668	Adapter, 5/8-inch to 1/2-inch NPT Male
13a	813-0616	Elbow, 1/2-inch X 90° SS
*	813-0899	Elbow, 1/2-inch X 90° SS (<i>used with 813-0905</i>)
*	813-0905	Nipple, 1/2-inch x 1.50 SS NPT
13b	813-0908	Adapter, 1/2-inch NPT M/T 90° (<i>used only on side next to cabinet</i>)
14	810-2944	Valve, 1/2-inch Ball
15	210-8999	Handle, Rear Flush Valve
16	210-9203	Retainer, Oil Return Valve Nut
17	813-0913	Nipple, 1/2-inch x 3.0-inch SS
18	810-3015	Manifold, Rear Oil Return Two-Station Fryer

8.8 Oil Disposal Plumbing

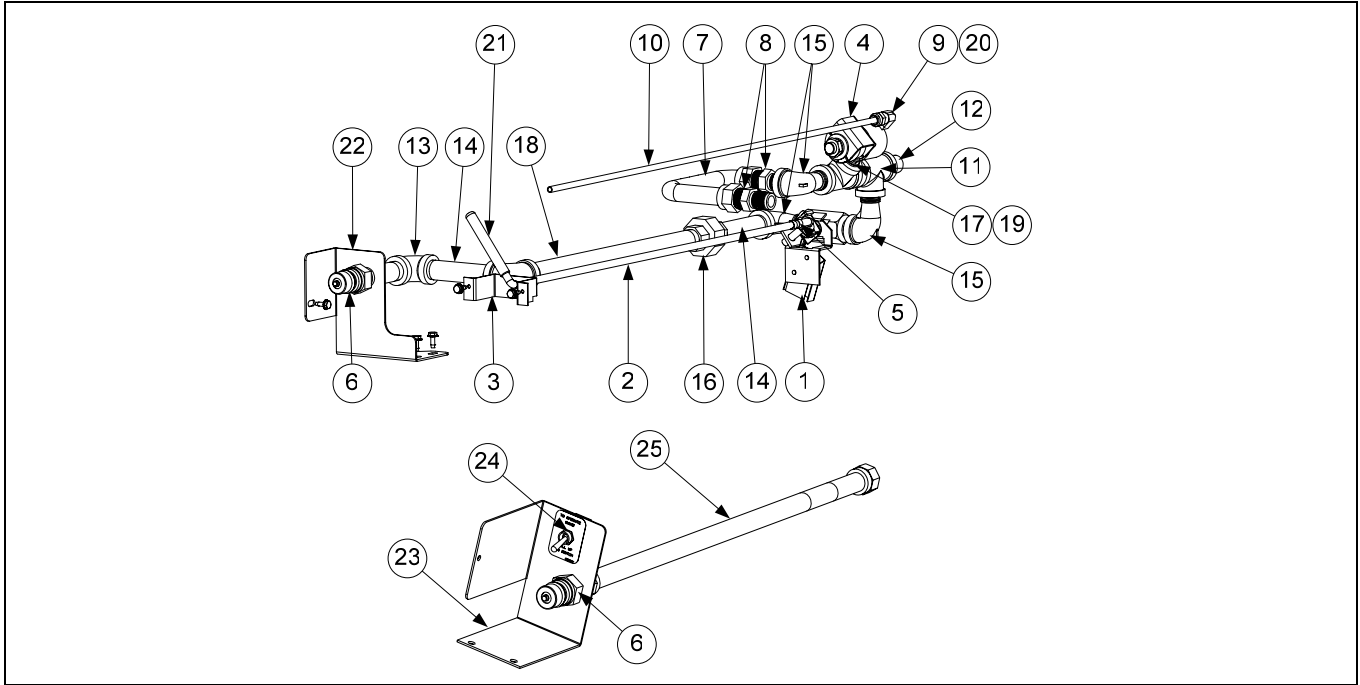

ITEM	PART #	COMPONENT
	106-5975	Plumbing, Front Oil Disposal (<i>use 106-6472 for Singles</i>)
1	106-5974	Valve Assembly, Oil Disposal
	810-2944	Valve ½-inch Ball SS
	807-2103	Microswitch
2	230-0985	Rod, Oil Disposal
3	230-0986	Bracket, Oil Disposal Rod
4	807-2484	Valve, Solenoid ¼-inch NPT
5	809-0601	Clip, Clevis Right Rod End
6	810-0487	Coupling, Male, Quick Disconnect
7	810-1043	Flexline, ½-inch ID x 9.50"
8	810-1668	Adaptor, Male ⅝-inch OD x ½-inch
9	810-2493	Fitting, 90° Quick Connect Tube
10	812-1803	Tubing, ¼-inch OD x 24.50" Teflon
11	813-2343	Tee, ½-inch x ½-inch x ½-inch SS
12	813-0900	Nipple, ½-inch x Close SS
13	813-0889	Elbow, ½-inch 90° SS
14	813-0901	Nipple, ½-inch x 4.0" SS
15	813-0616	Elbow, Street ½-inch x ½-inch NPT 90° SS
16	813-0902	Union, ½-inch NPT SS
17	813-0903	Bushing, ½-inch x ¼-inch SS Flush
18	813-0904	Nipple, ½-inch x 13.0" NPT SS
19	813-0905	Nipple, ¼-inch x 1½-inch SS
20	813-0807	Bushing, ¼-inch x ⅛-inch
21	816-0637	Cap, Vinyl Blue 5/16-inch x 3.0"
22	823-5693	Bracket, Assembly Quick Disconnect
23	823-5858	Bracket Mount Single RCCL
24	807-2106	Switch Toggle Single
25	810-1068	Flexline, ⅝-inch O.D. x 21.50-inch

8.9 Wiring Connectors, Pin Terminals, Seals, and Power Cords

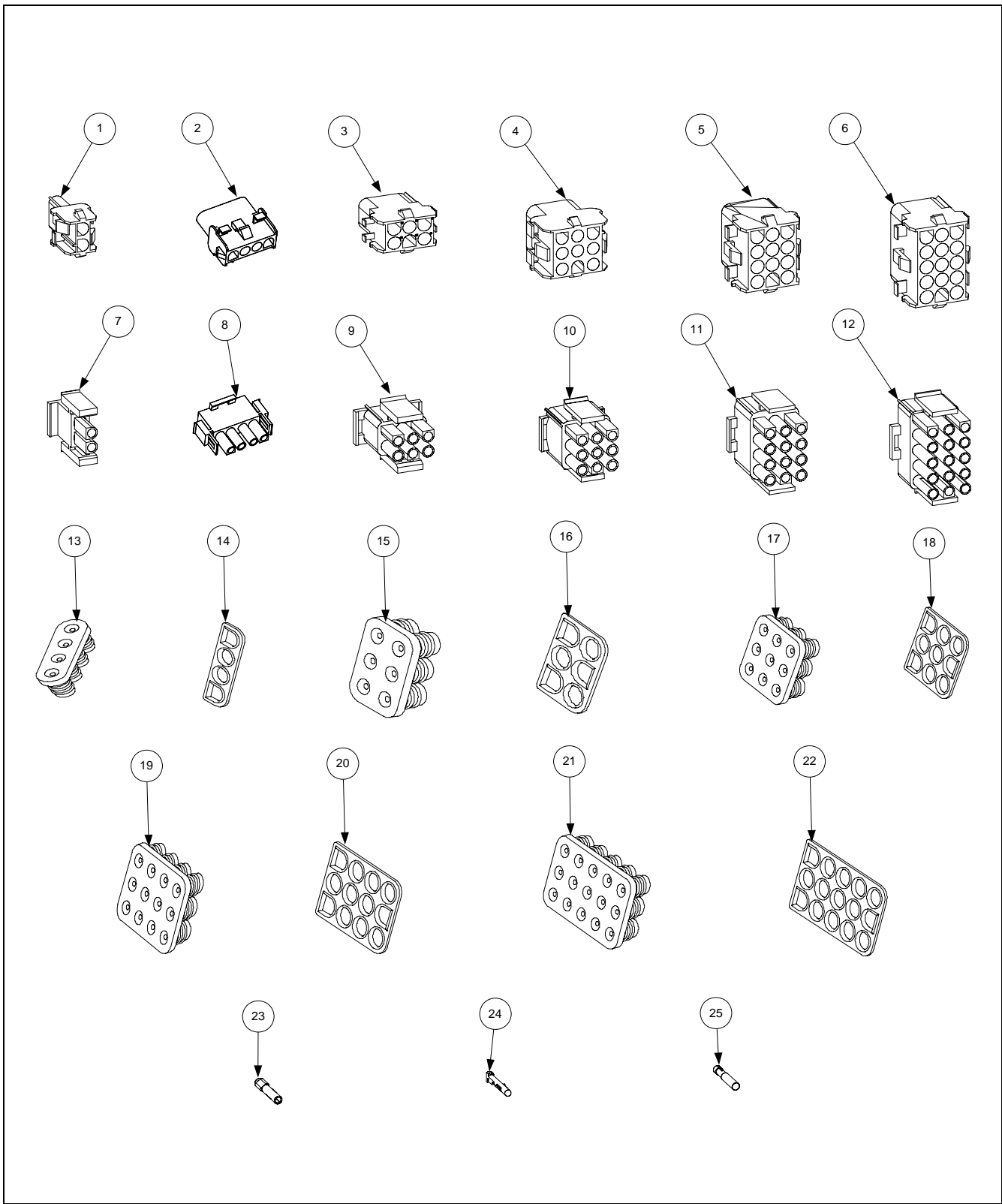

8.9 Wiring Connectors, Pin Terminals, Seals, and Power Cords cont.

ITEM	PART #	COMPONENT
		Power Cords
*	807-3834	Cable, 3-Phase 4-Wire (Fryer Power Cable)
*	106-6530	Cord, Filter System Power 220V 15A
		Connectors
1	807-1068	2-Pin Female
2	807-3232	4-Pin Female
3	807-0158	6-Pin Female
4	807-0156	9-Pin Female
5	807-0159	12-Pin Female
6	807-0875	15-Pin Female
7	807-1067	2-Pin Male
8	807-2078	4-Pin Male
9	807-0157	6-Pin Male
10	807-0155	9-Pin Male
11	807-0160	12-Pin Male
12	807-0804	15-Pin Male
		Universal Mate-N-Lock Seals
13	816-0675	4-Pin Wire Seal
14	816-0676	4-Pin Interface Connector Seal
15	816-0667	6-Pin Wire Seal
16	816-0668	6-Pin Interface Connector Seal
17	816-0669	9-Pin Wire Seal
18	816-0670	9-Pin Interface Connector Seal
19	816-0671	12-Pin Wire Seal
20	816-0672	12-Pin Interface Connector Seal
21	816-0673	15-Pin Wire Seal
22	816-0674	15-Pin Wire Seal
23	826-1341	Terminal, Female Split Pin (Pkg of 25)
24	826-1342	Terminal, Male Split Pin (Pkg of 25)
25	807-2518	Plug, Mate-N-Lock (Dummy Pin)

* Not illustrated.

8.10 Fasteners

ITEM	PART #	COMPONENT
*	809-0429	Bolt, 1/4-inch – 20 x 2.00-inch Hex Head ZP Tap
*	809-0514	Capscrew, 5/16-inch-18 NC Hex
*	809-0448	Clip, Tinnerman
*	826-1366	Nut, 4-40 Keps Hex (Pkg. of 25) (809-0237)
*	826-1358	Nut, 6-32 Keps Hex (Pkg. of 25) (809-0049)
*	809-0247	Nut, 8-32 Keps Hex
*	826-1376	Nut, 10-32 Keps Hex (Pkg. of 10) (809-0256)
*	809-0766	Nut, 10-32 Keps Hex SS
*	809-0581	Nut, 1/2 NPT Locking
*	809-0020	Nut Cap 10-24 NP
*	826-1372	Nut Grip 1/4-inch 1/4-20 Hex NP (Pkg. of 10) (809-0059)
*	809-0417	Nut Flange 1/4-inch 1/4-20 Serr
*	809-0535	Nut, "T" 1/4-inch-20 x 7/16 SS
*	809-0540	Nut, Lock 1/2-inch-13 Hex 2-Way ZP
*	826-1359	Screw, 4-40 x 3/4-inch Slotted Round Head (Pkg. of 25) (809-0354)
*	826-1365	Screw, 6-32 x 3/8-inch Slot Head (Pkg. of 25) (809-0095)
*	809-0357	Screw, 6 x 3/8-inch Phillips Head NP
*	809-0359	Screw, 8 x 1/4-inch Hex Washer Head
*	809-0360	Screw, 8 x 3/8-inch Hex Washer Slot Head
*	826-1371	Screw, 8 x 1/2-inch Hex Head ZP (Pkg. of 25) (809-0361)
*	809-0364	Screw, 8 x 5/8-inch Hex Washer Head ZP
*	809-0518	Screw, 8-32 x 3/8-inch Hex Washer Slotted Head SS
*	809-0104	Screw, 8-32 x 1/2-inch Slotted Head ZP
*	826-1363	Screw, 8-32 x 1/2-inch NP (Pkg. of 25) (809-0103)
*	826-1360	Screw, 10-24 x 5/16-inch Round Slot Head ZP (Pkg. of 25) (809-0024)
*	826-1330	Screw, 10-32 x 3/8-inch Slot Head SS (809-0117)
*	809-1003	Screw, 10-32 x 3/8-inch Hex Trim Head SS
*	826-1375	Screw, 10-32 x 3/4-inch Hex Trim Head SS (Pkg. of 5) (809-0401)
*	809-1000	Screw, 10-32 x 1 1/4-inch Hex Sck C/S
*	826-1374	Screw, 10 x 1/2-inch Hex Head (Pkg. of 25) (809-0412)
*	809-0266	Screw, 10 x 1/2-inch Phillips Head ZP
*	809-0434	Screw, 10 x 3/8-inch Hex Washer Head NP
*	809-0123	Screw, 10 x 3/4-inch Slot Head
*	826-1389	Screw, 1/4-20 x 3/4-inch Hex Head ZP (Pkg. of 10) (809-0131)
*	809-0582	Washer 1/2 NPT Locking
*	809-0184	Washer, #10 LK ZP
*	809-0190	Washer, .625 X .275 X 40 Flat SS
*	809-0191	Washer, Lock 1/4 Spring ZP
*	809-0193	Washer, Flat 1/4 Nylon
*	809-0194	Washer, Flat 5/16 ZP



Shipping Address: 8700 Line Avenue, Shreveport, Louisiana 71106

TEL 1-318-865-1711

FAX (Parts) 1-318-688-2200

(Tech Support) 1-318-219-7135

Email: service@frymaster.com

SERVICE HOTLINE
1-800-551-8633

819-6202A
NOVEMBER 2011